

ROBOTIC FISH WITH MACRO FIBER COMPOSITE PROPULSION SYSTEM

Jasfer Aniban, Adedolapo Awofiranye, Nanmwa Dala, Tianyuan Zhao, and Dr. Daewon Kim (Advisor)

Embry-Riddle Aeronautical University

The main objective of this project is to build and test a robotic fish with its propulsion system based on Macro Fiber Composites (MFC). These state-of-the-art actuators based on active materials offer several potential advantages for robotic fish applications compared to traditional servo motors. One important benefit is that smart actuators are lightweight and can be embedded directly into the structure of a fish torso or control surface. In addition, they are eco-friendly. Our goal is therefore to fabricate a robotic fish motion using biometric fish locomotion using MFCs.

Caudal fin - MacroFiber Composite (MFC) actuator

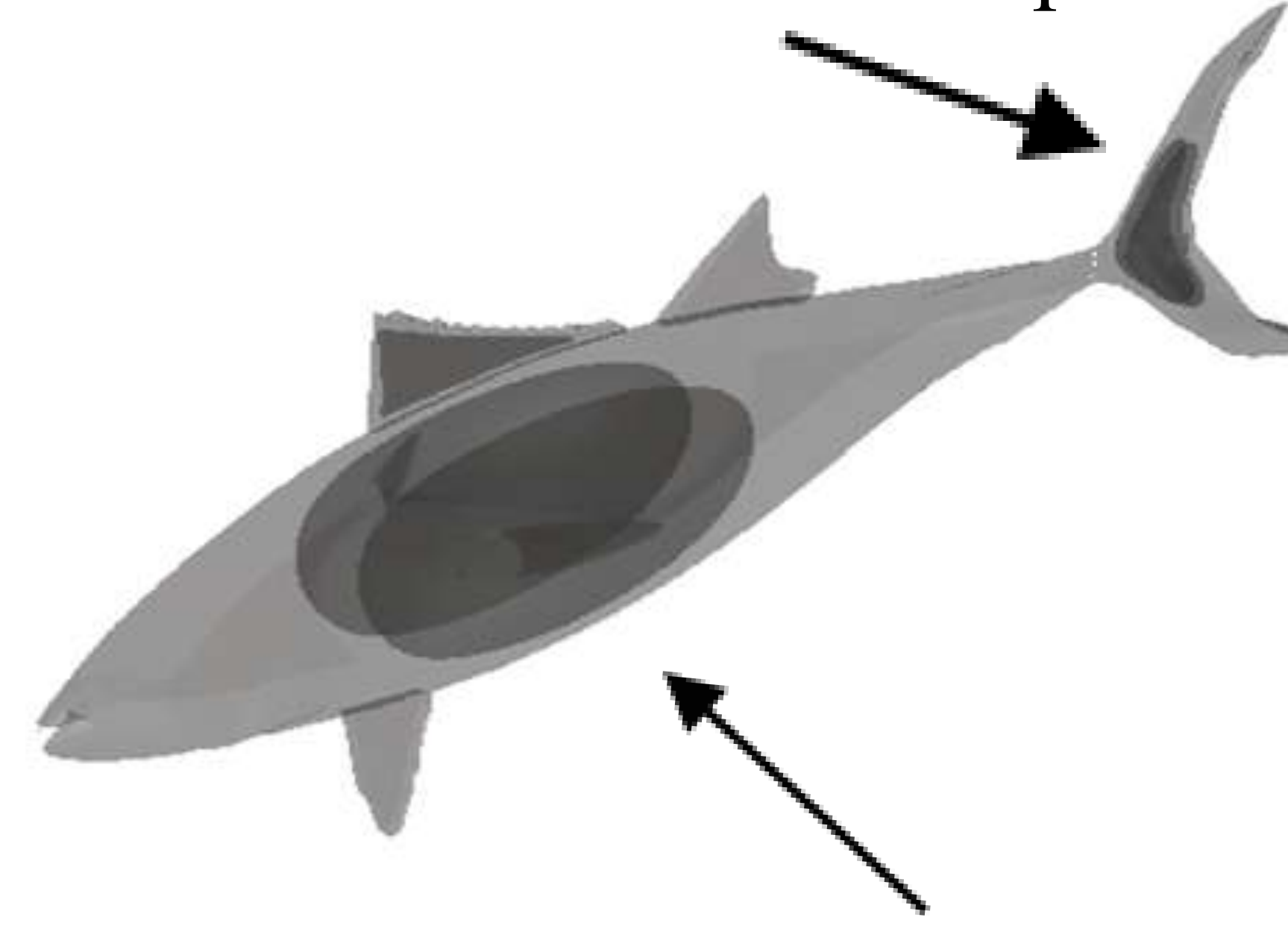

Electronic Control Unit (ECU) and ballast system

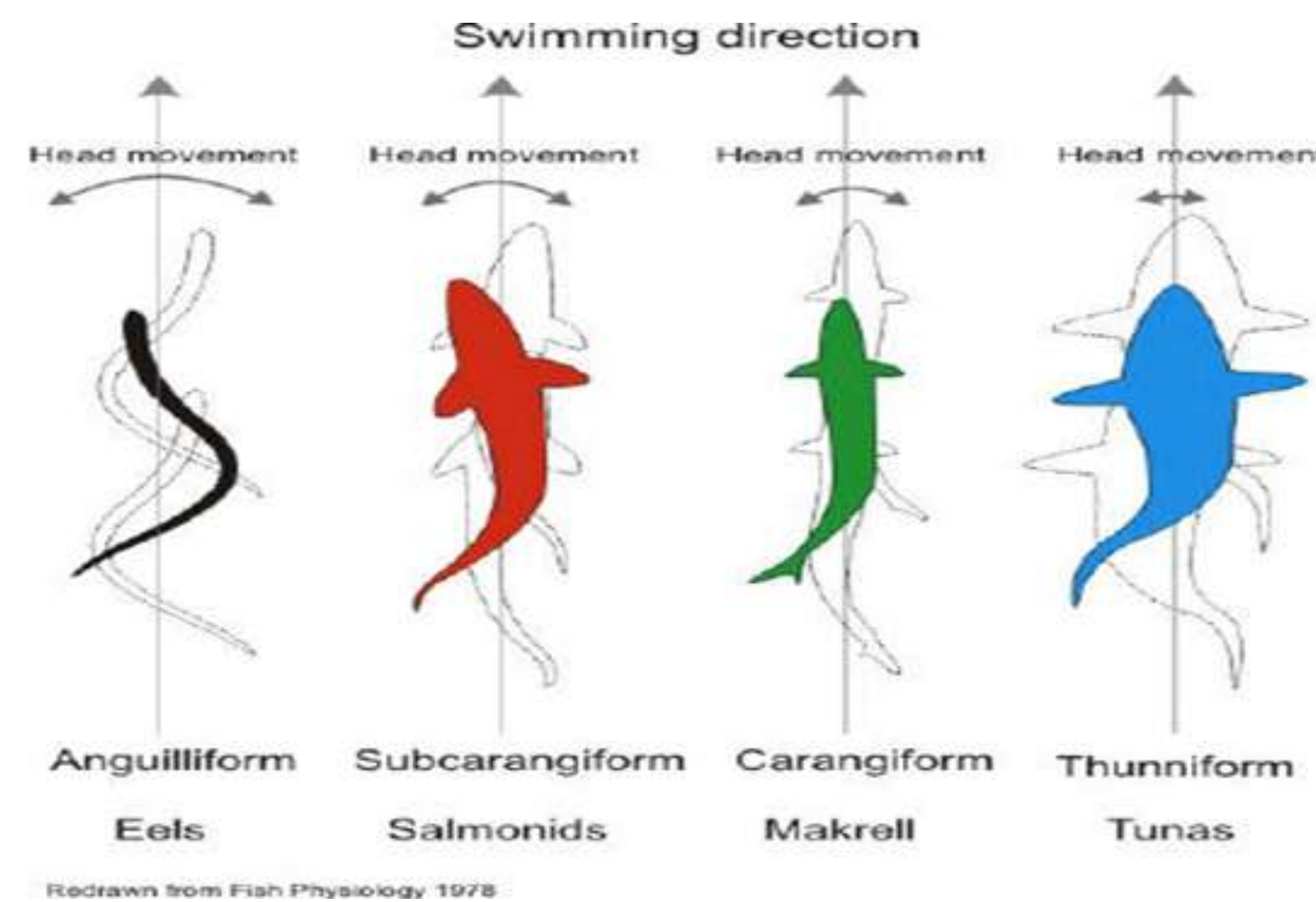
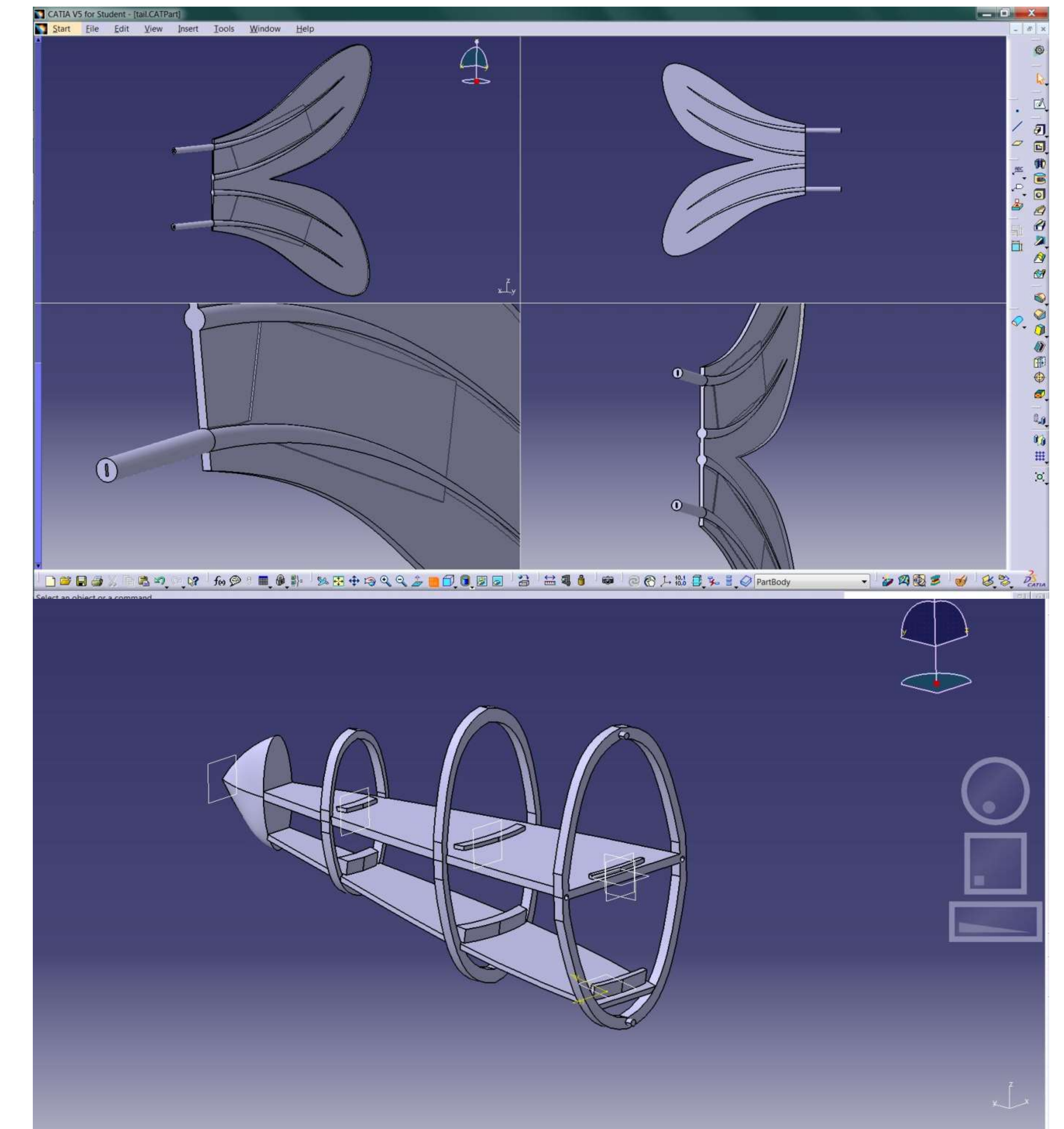
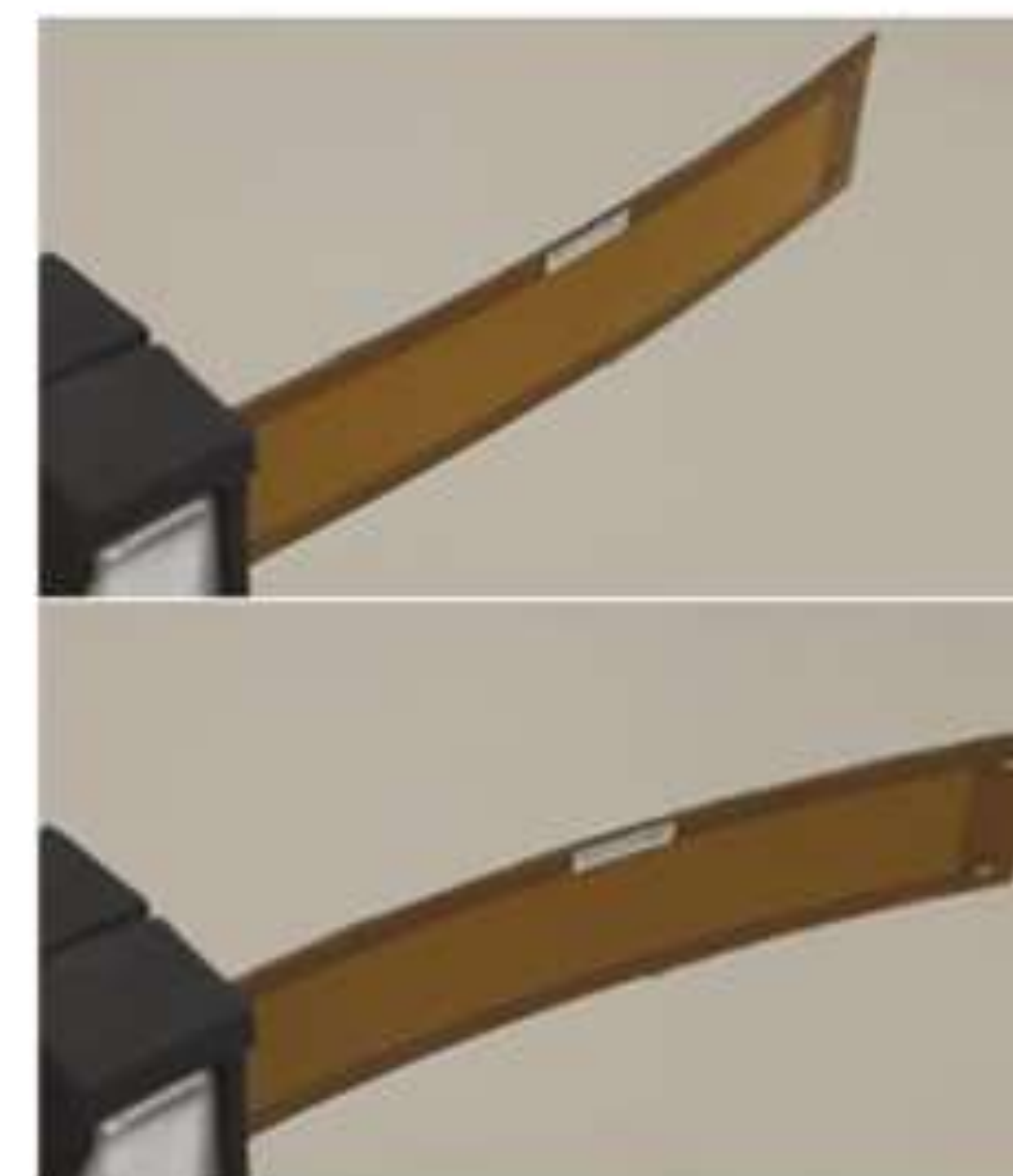

Obstacles:

- Rigidity of tail which decreases MFC deflection
- Limited maximum voltage lowers maximum MFC deflection
- Water-proofing the systems inside the fish
- Controlling the depth of the fish underwater using a ballast system

References:

- [1] Helfman, Collette. "Functional Morphology: Locomotion & Feeding." Hillsborough Community College. Web. 3 Mar 2014. <[https://www.hccfl.edu/media/469852/ch_8_\(functional_morphology-locomotion\).ppt](https://www.hccfl.edu/media/469852/ch_8_(functional_morphology-locomotion).ppt)>.
- [2] *Swimming direction*. 1978. Graphic. n.p. Web. 3 Mar 2014. <<http://esi.stanford.edu/exercise/exercise4.htm>>.
- [3] Awan, Mohsin. "Top 10 Fastest Fish in the World." *The top tenz explore your World*. Animals, Nature, 01 Nov 2012. Web. 3 Mar. 2014. <<http://thetoptenz.net/fastest-fish-in-world/>>.
- [4] Sfakiotakis, Michael, David Lane, and Bruce Davies. "Review of Fish Swimming modes for Aquatic Locomotion." *IEEE Journal of Oceanic Engineering*, n.d. Web. 3 Mar 2014. <http://www.societyofrobots.com/robottheory/Review_of_Fish_Swimming_Modes.pdf>.