

Fall 11-2015

## An Experimental Method to Calculate Coefficient of Friction in Mecanum Wheel Rollers and Cost Analysis Using DFMA Techniques

Nishant Sonawane  
*Embry-Riddle Aeronautical University*

Follow this and additional works at: <https://commons.erau.edu/edt>



Part of the [Mechanical Engineering Commons](#)

---

### Scholarly Commons Citation

Sonawane, Nishant, "An Experimental Method to Calculate Coefficient of Friction in Mecanum Wheel Rollers and Cost Analysis Using DFMA Techniques" (2015). *Doctoral Dissertations and Master's Theses*. 250.

<https://commons.erau.edu/edt/250>

This Thesis - Open Access is brought to you for free and open access by Scholarly Commons. It has been accepted for inclusion in Doctoral Dissertations and Master's Theses by an authorized administrator of Scholarly Commons. For more information, please contact [commons@erau.edu](mailto:commons@erau.edu).

An Experimental Method to Calculate Coefficient of Friction in Mecanum Wheel Rollers  
and Cost Analysis Using DFMA Techniques

A Thesis

Submitted to the Faculty

of

Embry-Riddle Aeronautical University

by

Nishant Sonawane

In Partial Fulfillment of the

Requirements for the Degree

of

Master of Science in Mechanical Engineering

December 2015

Embry-Riddle Aeronautical University

Daytona Beach, Florida

An Experimental Method to Calculate Coefficient of Friction in Mecanum Wheel Rollers  
and Cost Analysis Using DFMA Techniques

by

Nishant Sonawane

A Thesis prepared under the direction of committee chairman, Dr. Sathya Gangadharan, Department of Mechanical Engineering and has been approved by the members of the thesis committee. It was submitted to the School of Graduate Studies and Research and was accepted in partial fulfillment of the requirements for the degree of Master of Science in Mechanical Engineering.

THESIS COMMITTEE

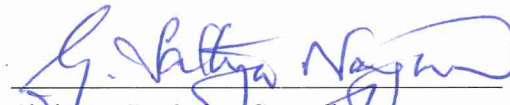
  
Chairman, Dr. Sathya Gangadharan

  
Member, Dr. Birce Dikici

  
Member, Dr. Ilteris Demirkiran

  
Department Chair, Dr. Charles F. Reinholtz  
Mechanical Engineering

12/3/15  
Date

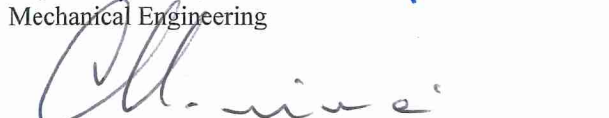
  
Dean of College of Engineering, Dr. Maj Mirmirani

12/3/15  
Date

  
Associate VP for Academics, Dr. Christopher Grant

12/4/15  
Date

This thesis is dedicated to my parents and extended family for their continuous support and love. Their scarification regarding my career cannot be thanked in words.

This work is also dedicated to all my professors for their guidance and help in my path to success.

## ACKNOWLEDGMENTS

First and most important, I would like to thank God for giving me the strength and power to be able to work on such a great platform and prove my capabilities to world. I would like to thank my family for their support, without whom it was difficult task to continue my study.

I would like to convey my kind appreciation to my thesis advisor Dr. Sathya Gangadharan for letting me work on this topic and for his strong support, guidance, help and encouragement for this research work. I would like to thank to all special people whose impact on my academic life changed the way I look the mechanical engineering field as my career. I am very thankful to Dr. Birce Dikici and Dr. Ilteris Demirkiran for accepting my invitation to become committee member and supporting me in this thesis work.

I would like to convey my humblest thanks to Mr. Keith Schlee, Vice President of Helical Robotics for introducing me to this fantastic world of Mecanum wheels and robots. To be able to work on such futuristic things and technology an as a student it was really unbelievable experience. Despite his busy schedule, Mr. Keith provided guidance and help on this research. Once again I want to thank him for giving me opportunity to work with him.

# CONTENTS

NOMENCLATURE.....	vii
LIST OF FIGURES .....	viii
LIST OF TABLES.....	x
ABSTRACT.....	xi
<b>1. Introduction .....</b>	<b>12</b>
<b>1.1. Overview .....</b>	<b>12</b>
<b>1.2. Background .....</b>	<b>12</b>
<b>1.2.1. Force.....</b>	<b>12</b>
<b>1.2.2. Friction .....</b>	<b>13</b>
<b>1.2.3. Traction .....</b>	<b>14</b>
<b>2. Mecanum Wheel .....</b>	<b>16</b>
<b>2.1.1. Motion.....</b>	<b>18</b>
<b>2.1.2. Control Mechanism.....</b>	<b>20</b>
<b>2.1.3. Force Distribution on Mecanum Wheel Roller .....</b>	<b>25</b>
<b>2.1.4. Mecanum Wheel Traction Factor.....</b>	<b>25</b>
<b>2.1.5. Material for Roller.....</b>	<b>26</b>
<b>2.1.6. Mecanum Plate .....</b>	<b>29</b>
<b>2.1.7. Brass Sleeve &amp; Bearing .....</b>	<b>29</b>
<b>3. Kinematic Model.....</b>	<b>31</b>
<b>3.1. Model .....</b>	<b>31</b>
<b>3.2. Forces .....</b>	<b>32</b>
<b>3.3. Wheel Velocity.....</b>	<b>34</b>
<b>3.4. Roller Surface Geometry .....</b>	<b>34</b>
<b>4. Manufacturing .....</b>	<b>36</b>
<b>4.1. Wheel Plate.....</b>	<b>36</b>
<b>4.2. Rollers .....</b>	<b>37</b>

4.3.	Brass Sleeves .....	37
5.	Experiment to Determine the Coefficient of Friction .....	38
5.1.	Overview.....	38
5.1.1.	Experiment Process .....	40
5.1.2.	Machine Specification.....	41
5.1.3.	Case 1 - Coefficient of Friction on Concrete Base.....	45
5.1.4.	Case 2 - Coefficient of Friction on Aluminum Plate .....	46
5.1.5.	Case 3 - Coefficient of Friction on Wet Surface .....	47
5.1.6.	Case 4 - Coefficient of Friction on Fine Finished Wooden Plate .....	48
5.1.7.	Case 5 - Coefficient of Friction on Painted Surface.....	49
5.1.8.	Case 6 - Coefficient of Friction on Ice .....	50
5.1.9.	Case 7 - Coefficient of Friction on Hot Surface (65.55 <sup>0</sup> C).....	52
5.1.10.	Case 8 - Coefficient of Friction on Greasy Surface .....	53
5.1.11.	Case 9 - Coefficient of Friction of Rollers on Sand Paper with Grit-220.....	54
6.	Mecanum Wheel Life Span.....	58
6.1.	Side Peel of Rollers.....	58
6.1.1.	Theory for Side Peel Effect.....	59
6.1.2.	Observation & Results .....	59
7.	Design for Manufacturing and Assembly .....	61
7.1.	DFM .....	61
7.1.	DFA.....	65
8.	Conclusion.....	68
9.	Future Suggestions.....	71
	REFERENCE.....	72
	APPENDIX A .....	74
	APPENDIX B.....	77
	APPENDIX C .....	80

## NOMENCLATURE

DFM = Design for Manufacturing

DFA = Design for Assembly

C.O.F = Coefficient of Friction

F = Applied Force (N)

$F_c$  = Reaction Force (N)

$\mu$  = Coefficient of Friction

W = Weight (kg)

$\omega$  = Rotational Velocity (rad/s)

x, y = Co-Ordinate System

$M_1, M_2, M_3, M_4$  = Motors for Four Wheels

$V_t$  = Velocity (m/s)

ABS = Acrylonitrile Butadiene Styrene

SBR = Styrene and Butadiene Rubber

$R_i$  = Radius for 'i' wheel (m)

$\alpha, \beta$  = Angle Between Chassis and Roller Axis

$\tau$  = Torque (N.m)

$\phi$  = Angle between x-y Co-Ordinates to Chassis Center

S = Resultant Displacement (m)

P = Load on the Roller (N)



## LIST OF FIGURES

Figure 1.1 Free Body Diagram of Mass on Flat Surface.....	11
Figure 1.2 Mecanum Wheel with Rollers.....	14
Figure 1.3 Assembled Roller Parts.....	15
Figure 1.4 Saperated Parts for One Roller.....	16
Figure 1.5 Vehicle Motion.....	17
Figure 1.6 Drive Motion.....	18
Figure 1.7 Mecanum Wheel Layout.....	20
Figure 1.8 Force Vector on Right Mecanum Wheel.....	21
Figure 1.9 Force Vector on Left Mecanum Wheel.....	23
Figure 2.0 Force Vectors on Single Roller.....	25
Figure 2.1 Dimensions of Brass Sleeve & Bearing.....	30
Figure 2.2 Mecanum Robot & Wheel Specification with Co-Ordinates.....	31
Figure 2.3 Force Distribution.....	33
Figure 2.4 Displacement Vector.....	34
Figure 2.5 Roller Profile.....	35
Figure 2.6 Tools for Experiment.....	42
Figure 2.7 Roller with Attachment for Experiment.....	42
Figure 2.8 Mecanum Wheel of 6".....	43
Figure 2.9 Mecanum Wheel of 9".....	43
Figure 3.0 Surface Bed to Calculate C.O.F.....	44
Figure 3.1 Experiment Tool for Length Measurement.....	44
Figure 3.2 Coefficient of Friction on Concrete Surface.....	45
Figure 3.3 Coefficient of Friction on Aluminum.....	47
Figure 3.4 Coefficient of Friction on Wet Surface.....	48
Figure 3.5 Coefficient of Friction on Wooden Surface.....	49
Figure 3.6 Coefficient of Friction on Painted Surface.....	50
Figure 3.7 Coefficient of Friction on Ice Surface.....	52
Figure 3.8 Coefficient of Friction for Hot Surface at 65.55 <sup>0</sup> C.....	53
Figure 3.9 Coefficient of Friction on Greasy Surface.....	54

Figure 4.0 Sand Paper with Grit - 40.....	55
Figure 4.1 Sand Paper with Grit - 600.....	55
Figure 4.2 Coefficient of Friction on Sand Paper with Grit - 220.....	56
Figure 4.3 Wearing of Rollers.....	60
Figure 4.4 User Interface of DFM Software.....	62
Figure 4.5 Process and Material Selection in DFM.....	64
Figure 4.6 DFA Software Analysis Chart.....	66
Figure 4.7 Manufacturing Cost per Product.....	73
Figure 4.8 DFM Cost Breakdown.....	74
Figure 4.9 Process Chart for Mecanum Plate Manufacturing.....	75
Figure 5.0 DFM Analysis for Injection Molding.....	76
Figure 5.1 DFM Report for Manufacturing Factors of Rollers.....	77
Figure 5.2 DFM Analysis of Cost Distribution.....	78
Figure 5.3 DFA Assembly Labor Time.....	79
Figure 5.4 DFA for Part per Production Assembly.....	80
Figure 5.5 DFA Result for Production Cost with Tooling Investment.....	81
Figure 5.6 DFA Comparison of Different Product Assembly Processes.....	82

## LIST OF TABLES

Table 1.1 Mecanum Wheel Specifications for 6" Wheel.....	16
Table 1.2 Part Count of One Mecanum Wheel.....	17
Table 1.3 Drive Mechanism for Mecanum Wheel Robot.....	20
Table 1.4 Physical Properties of Polyurethane.....	27
Table 1.5 ABS Material Properties.....	28
Table 1.6 Properties for SBR Rubber.....	29
Table 1.7 Friction Tester Specification.....	41
Table 1.8 Important Friction Factor.....	57
Table 1.9 Friction Value Comparison.....	57
Table 2.0 DFM Analysis of Roller Material.....	67

## **ABSTRACT**

Researcher: Nishant Hiranman Sonawane

Title: An Experimental Method to Calculate Coefficient of Friction in Mecanum  
Wheel Rollers and Cost Analysis Using DFMA Techniques

Institute: Embry-Riddle Aeronautical University

Degree: Master of Science in Mechanical Engineering M.S.M.E

Year: 2015

Mecanum wheel is a special kind of Omni-directional wheel which is designed for robot vehicles. The purpose of this thesis is to work on geometry and working of Mecanum wheel rollers and to conduct experiments on these rollers to find its values of coefficient of friction in different conditions. This thesis also includes the work conducted to formulate the equations which can be used to find different parameters of roller for its motion, kinematics, rolling, friction and overall impact with respect to the working of a robot. The work is tested in experiments and the values are compared with previous research values to validate the data. At the end, the derived components are tested in DFM (Design for Manufacturing) and DFA (Design for Assembly) to calculate all possible cost factors in manufacturing and assembly of rollers. This research is done with the support of a company called Helical Robotics. Helical Robotics is a leading manufacturer of Mecanum wheels and robots.

## **1. Introduction**

### **1.1. Overview**

The research work is concerned with an experiment to find coefficient of friction on Mecanum wheel rollers and its manufacturing and assembly analysis using DFM and DFA software. Mecanum wheel rollers are tested in different natural environmental conditions and its impact on the working of a robot. It is an experimental way to find out how friction force and other factors work on a wheel while the object is in motion and while the roller is used on different surfaces. All the work is conducted under guidance of company named as Helical Robotics located in Tampa. The main objective of working on Mecanum wheels is that the currently manufactured wheels have not been tested for different working environments and for a variety of load applied on robots. Helical robotics is working on finding the solution to calculate all the required data from wheels to calculate the total life span of rollers. The determination of total load, frictional force and traction in roller gives a chance to discuss more about manufacturing techniques and the material selection of Mecanum wheels. Mecanum wheels are currently being manufactured by company called as AndyMark. They manufacture wheels with different dimensions and provide all the specifications about the wheels.

### **1.2. Background**

#### **1.2.1. Force**

A force is a push or pull upon an object resulting from the object's interaction with another object. Whenever there is an interaction between two objects, there is a force upon each of the objects. Force and velocity are vector quantities which means that they

have both magnitude and direction. There are different types of forces which act on any object such as gravitational force and normal force. Gravitational force can be explained as attractive force which acts on two masses. Normal force can be explained as the force which acts perpendicularly on given object due to sliding effect of one object on other surface.

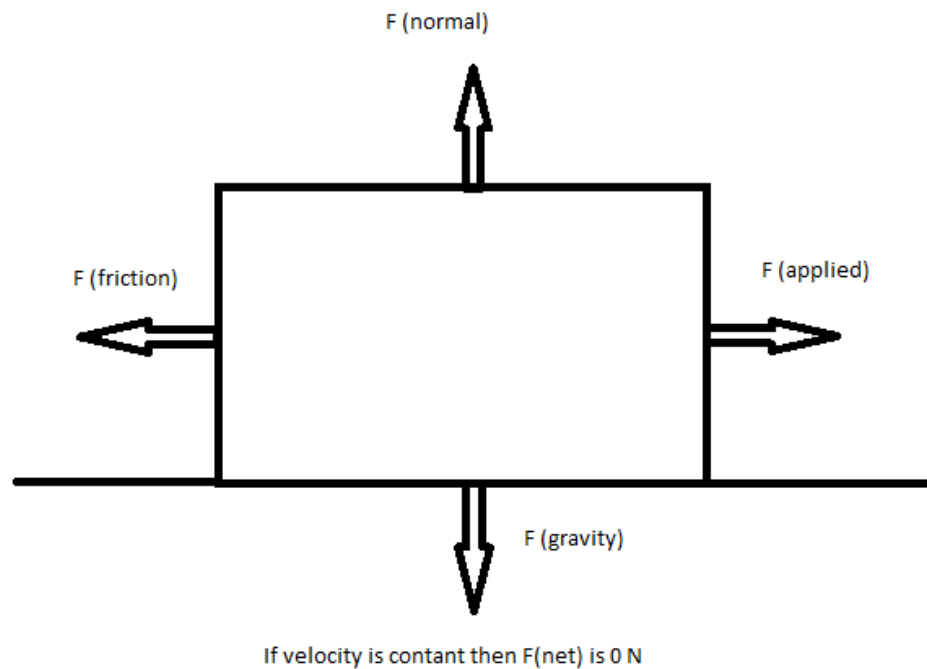

Figure 1.1 Free-body Diagram of Mass on Surface

### 1.2.2. Friction

Friction term can be divided into two types as static friction and kinetic friction. If the friction is considered while object is at rest then it is known as static friction. If the same object is considered in motion then it will give kinetic friction value: [1].

#### Static friction

If any object is pushed from the state of rest then for the object to move, it is necessary to overcome static friction.

$$F_s \leq \mu_s N \dots\dots\dots (1)$$

Where  $\mu_s$  is coefficient of static friction and  $F_s$  is maximum static force required.

Kinetic friction

Kinetic force comes into existence when object starts moving. The factor  $f_k$  which is known as kinetic coefficient of friction. Static friction coefficient is greater than the kinetic coefficient of friction: [1].

$$F_k = \mu_k N \dots\dots\dots (2)$$

Rolling Friction

Rolling friction is special type of kinetic friction. To explain that wheel is rotating without slipping this term is implied to show that wheel is subjected to rolling friction: [1].

**1.2.3. Traction**

There is a difference between friction and traction. Both terms are related with the contact of two surfaces and motion of those surfaces over each other with respect to speed and other considered factors. Friction is known as the force which opposes the motion of any given surface over other surface. Frictional force is always in opposite direction of motion: [2]. Traction is the friction between rotating surface on any given surface so that amount of force a wheel can apply to given surface before it slips. It can be concluded that for more traction, more friction is required between two surfaces: [3]. If there is less friction, there are more chances of wheel to slip and there will be less gripping force of one surface over another.

To calculate traction force the following formula is used:

$$F = \mu_t W \dots\dots\dots (3)$$

Where,

F = Traction effort in N

$\mu_t$  = Adhesion coefficient

w = Weight on the wheel in N

‘w’ can be written as product of mass (m) & acceleration of gravity, g (m/s<sup>2</sup>)



## 2. Mecanum Wheel

Mecanum wheel is special purpose wheel which is designed to move in any direction. All four wheels can be operated with separate motors which makes Mecanum wheels very versatile in applications. Mecanum wheel is also called as Iion wheel as Bengt Iion, a Swedish inventor developed them: [4]. The design of Mecanum wheel is unique. On the periphery of wheel are small rollers mounted with  $45^\circ$  axis of rotation to the plane of wheel. These rollers are  $45^\circ$  inclined to the line through the center of roller parallel to its axis of rotation of the wheel.

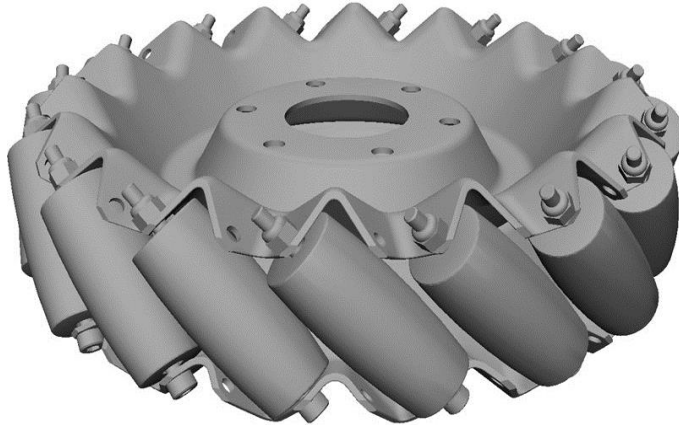

Figure 1.2 Mecanum Wheel with Rollers: [4].

Table 1.1 Mecanum Wheel Specifications for 6" Wheel

Diameter: 151mm
Width at rollers: 45.466 mm
Bore: 28.6mm
Bolt pattern: 5.08 mm diameter holes on 47.625 mm bolt circle
Body material: Steel, 12.7 mm thick
Number of rollers: 16
Roller material, outside: SBR Rubber
Roller Durometer: 75A
Roller Axle: M3 $\times$ 0.5 SHCS $\times$ 50mm long

Table 1.2 Part Count of One Mecanum Wheel

One – Mecanum Wheel Plate
Sixteen – Individual M3 × 0.5 SHCS × 50mm long screws
Sixteen – Individual M3 Nylock Nut, Steel, Zinc Plated Screws
Sixteen – Individual HD Mecanum Rollers
Sixteen – Individual 39.116 mm Brass Tubes
Sixteen – Individual 38.1 mm Brass Tubes

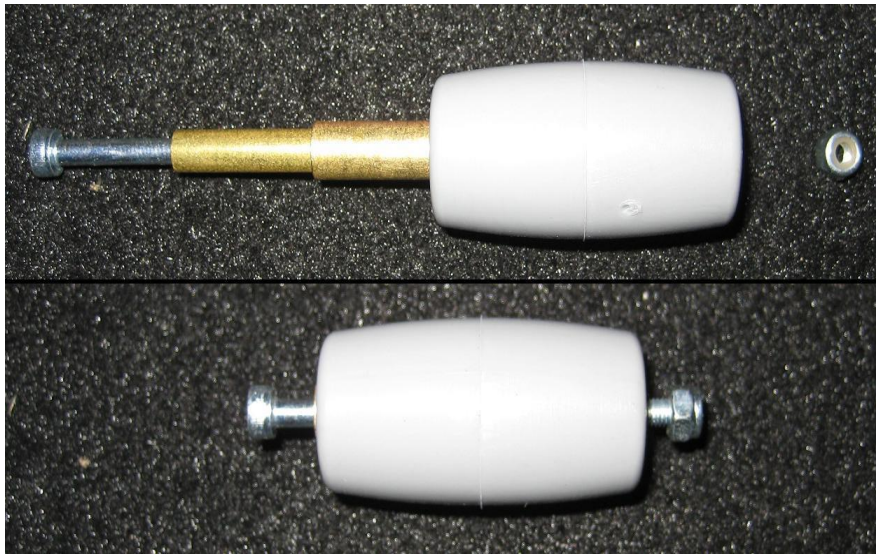

Figure 1.3 Assembled Roller Parts



Figure 1.4 Separated Parts for One Roller

### 2.1.1. Motion

Robot with Mecanum wheel assembly includes chassis and two wheels on each side. By use of these wheels as Omni-directional motion, it can drive the robot without conventional steering system: [4]. This system makes robotic motion in any direction possible as forward, backward, sideways to left or right. This design can provide a great flexibility for company environment and work floor. The motion of robot with Mecanum wheel is given in following diagram: [4].

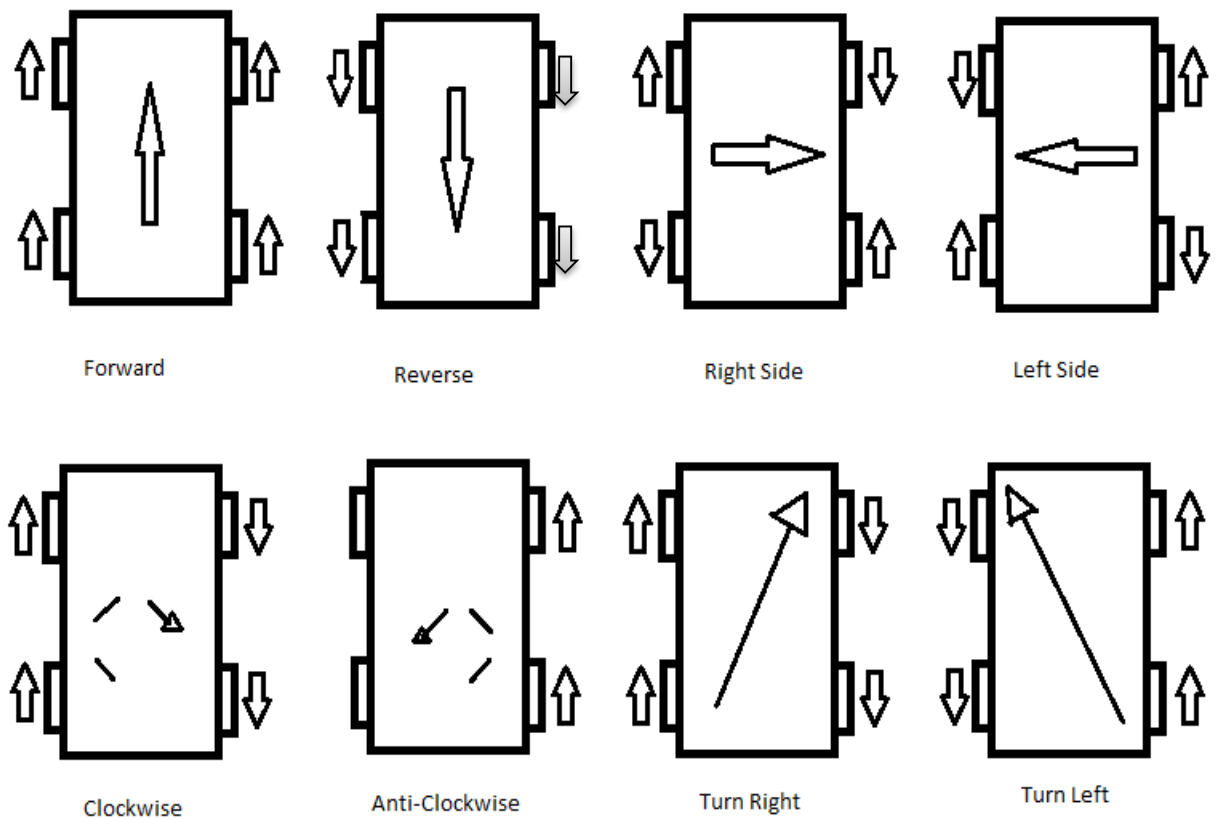

Figure 1.5 Vehicle Motion

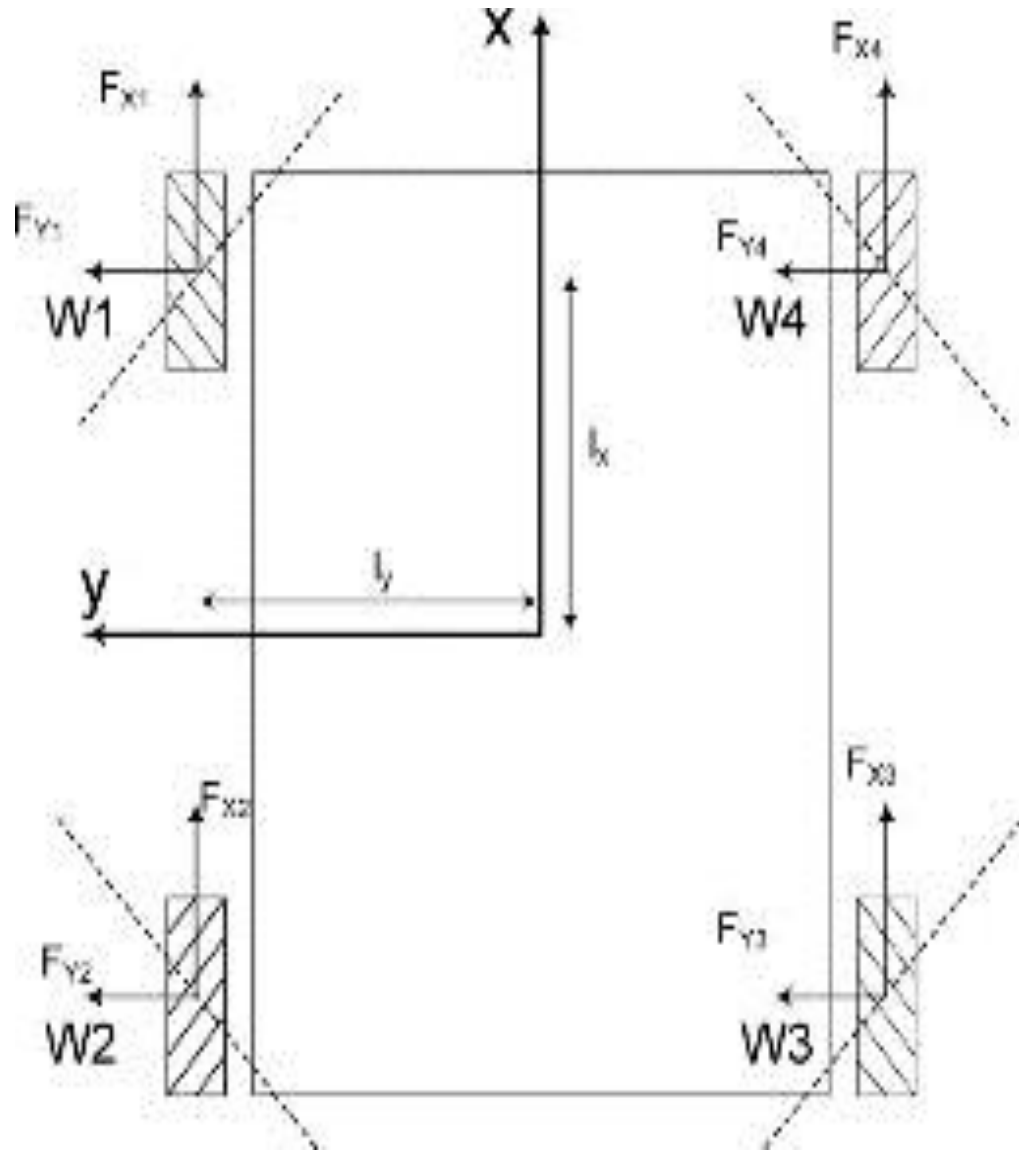

Figure 1.6 Drive Motion

This shows basic robot structure with rollers named from  $W1$  to  $W4$ .

To explain the motion of robot in specific direction following chart is given.

Table 1.3 Drive Mechanism for Mecanum Wheel Robot

<b>Movement</b>	<b>Wheel rotations</b>
Forward	All wheel moving forward with same speed
Reverse	Backward motion of wheels with same speed
Right Shift	2,3 backwards and 1,4 forward
Left Shift	1,4 backwards and 2,3 forward
Clockwise Turn	2,4 backwards and 1,3 forward
Counter Clockwise Turn	1,3 backwards and 2,4 forward

### 2.1.2. Control Mechanism

Control mechanism gives kinematic equations which are involved in finding the motion of vehicle. The detailed work for control of all motors is given with respect on x, y, w (longitudinal, lateral and yaw) input. Figure 1.7 provides information on force vectors due to result of robot's forward motion: [5]. In case of moving robot in forward motion, it is required to rotate all four wheels in forward direction. Same case is considered with backward motion in which it is necessary to move all wheels to backward direction. Remaining all other motions are provided in Table 1.3. The different directions can be obtained by operating required motor number in sequence. The motion of robot in any direction is very smooth as only four points touches the surface. Giving proper push or pull the wheels can slide or rotate as per requirement. This distinct feature of Mecanum wheel is very useful in futuristic applications.

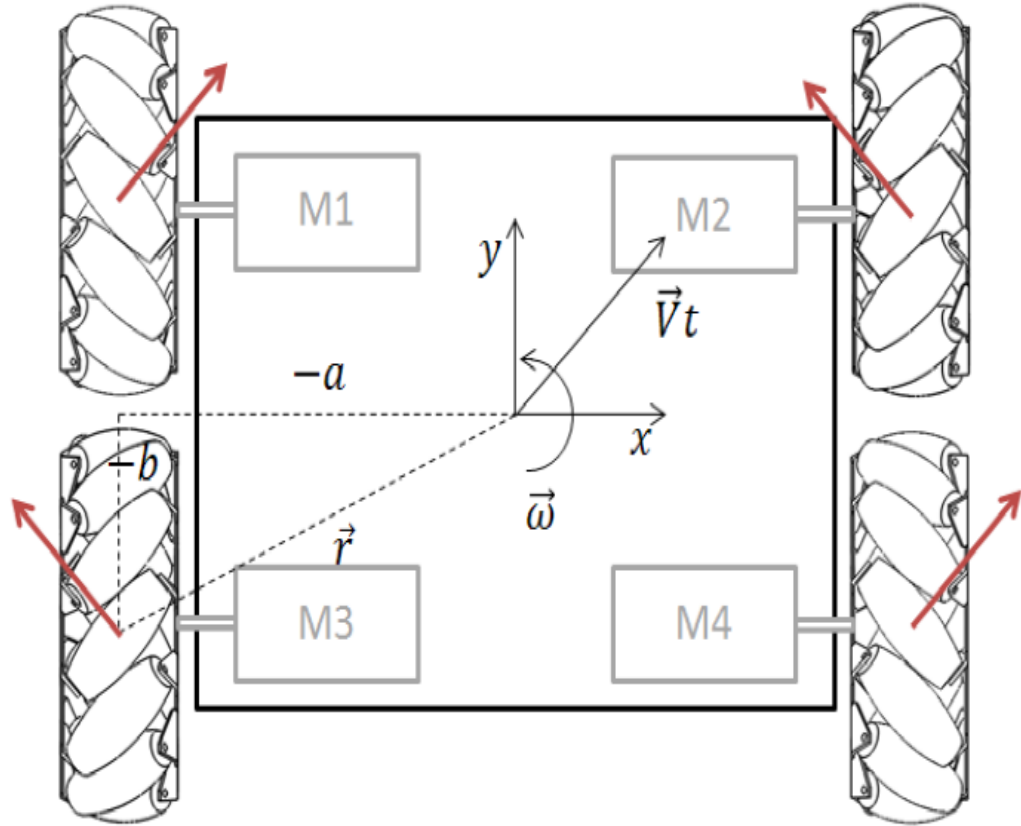

Figure 1.7 Mecanum Wheel Layout: [6].

' $V_t$ ' is desired velocity and ' $\omega$ ' is rotational velocity of platform and ' $r$ ' is given distance from center of platform to wheel contact point.

M1, M2, M3, M4 are four sets of motor attached with respective wheels.

This gives the scalar components as:

$$V_x = V_{tx} - \omega * (r * y) \dots \dots \dots (4)$$

$$V_y = V_{ty} - \omega * (r * x) \dots \dots \dots (5)$$

The force vector analysis acting on right Mecanum wheel can be given in following format.

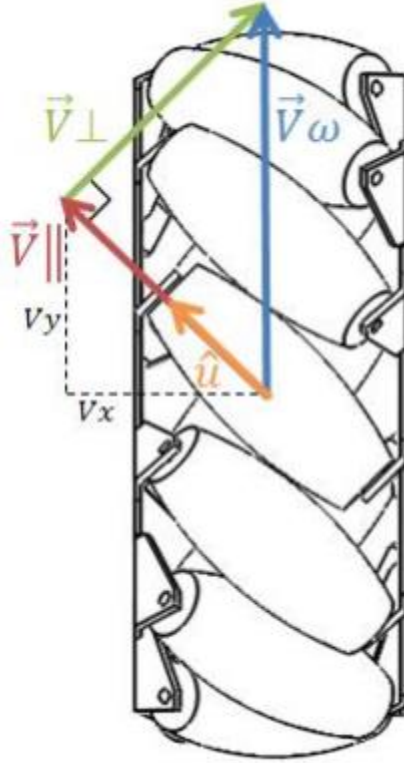

Figure 1.8 Force Vector on Right Mecanum Wheel

To calculate  $V_{\omega}$  for right wheel:

$$\cos 45 = \frac{V}{V_{\omega}} \dots \dots \dots (6)$$

$$V_{\omega} = \frac{V}{\cos 45} \dots \dots \dots (7)$$

$$V = -V_x \cos 45 + V_y \cos 45 \dots \dots \dots (8)$$

$$V_{\omega} = \frac{-V_x \cos 45 + V_y \cos 45}{\cos 45} \dots \dots \dots (9)$$

$$V_{\omega} = \sqrt{2} \left( -\frac{1}{\sqrt{2}} V_x + \frac{1}{\sqrt{2}} V_y \right) \dots \dots \dots (10)$$

$$V_{\omega} = -V_x + V_y \dots \dots \dots (11)$$

The two motors that use this wheel orientation are the right front & left rear.

$$a = r * x \dots\dots\dots (12)$$

$$b = r * y \dots\dots\dots (13)$$

Right front motor:

$$V_2X = V_tX - (\omega * b) \dots\dots\dots (14)$$

$$V_2Y = V_tY + (\omega * a) \dots\dots\dots (15)$$

Left front motor:

$$V_3X = V_tX - (\omega)(-b) \dots\dots\dots (16)$$

$$V_3Y = V_tY + (\omega)(-a) \dots\dots\dots (17)$$

The force vector analysis on left Mecanum wheel is provided: [6].

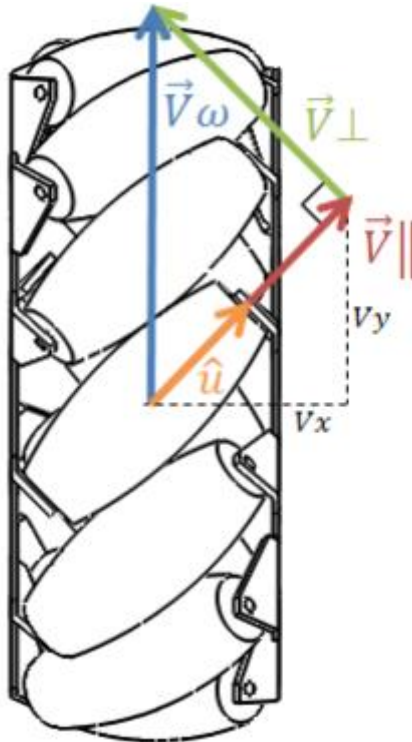

Figure 1.9 Force Vector on Left Mecanum Wheel

The calculation of  $V\omega$  for left wheel:

$$V = \frac{1}{\sqrt{2}} V_x + \frac{1}{\sqrt{2}} V_y \dots\dots\dots (18)$$



$$V_{\omega} = \frac{|V|}{\frac{1}{\sqrt{2}}} \dots \dots \dots (19)$$

$$V_{\omega} = V_x + V_y \dots \dots \dots (20)$$

Left front motor:

$$V_1X = V_tX - (\omega) * (b)$$

$$V_1Y = V_tY + (\omega)(-a)$$

Right rear motor:

$$V_4X = V_tX - (\omega * b)$$

$$V_4Y = V_tY + (\omega * a)$$

The result for complete kinematic equations is given in following equations:

$$V_1\omega = V_tY + V_tX - \omega(a + b)$$

$$V_2\omega = V_tY - V_tX + \omega(a + b)$$

$$V_3\omega = V_tY - V_tX - \omega(a + b)$$

$$V_4\omega = V_tY + V_tX + \omega(a + b)$$

[\*note: some values are given in bold letters, those parameters are vector quantities.]

### 2.1.3. Force Distribution on Mecanum Wheel Roller

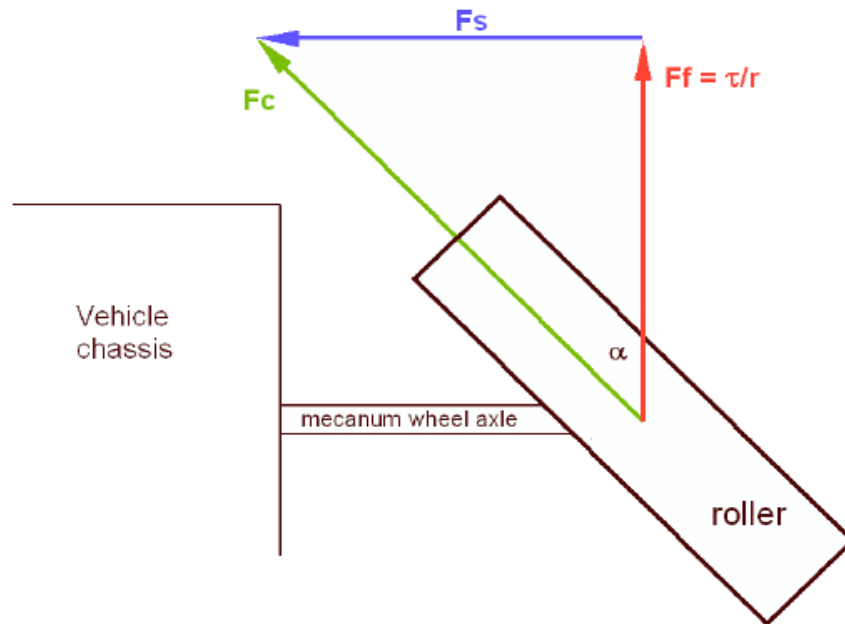

Figure 2.0 Force Vectors on Single Roller: [7].

Figure 2.0 shows that the roller is attached to axle and plate at an angle of 45 degrees which is given by  $\alpha$ .

$F_c$  is the reaction force of floor on bottom of roller.  $F_c$  has two components named  $F_s$  &  $F_f$ .  $F_s$  gets counterbalanced by an equal but opposite force from wheel on other side of vehicle.  $F_f$  is forward component which acts in the plane of Mecanum wheel. To counter balance the torque action on wheel,  $F_c$  must be equal to  $F_f/\cos(\alpha)$ .

### 2.1.4. Mecanum Wheel Traction Factor

The forward force which comes from wheel is equal to the forward force which comes by standard wheel of same dimension driven with same torque. In case of Mecanum wheel, reaction force between floor and wheel is greater by a factor  $1/\cos(\alpha)$ . It allows wheel to break the friction with floor and allows it to slip at lower forward force levels than a standard wheel. This phenomenon makes Mecanum wheel to work with less friction.

### 2.1.5. **Material for Roller**

Rollers are manufactured with 75A – 85A polyurethane material. Polyurethane is a polymer with numerous industrial applications because of its properties. On the inner side of polyurethane wheel is the hard ABS material. These Mecanum rollers are also made up of SBR rubber.

The others are manufactured by molding. As the material is perfect for melting and pouring into molds which then gets the mold shape. This technology is an economical way to manufacture the rollers. Then polyurethane and ABS are applied on each other's surface which makes ABS material to stick to polyurethane.

#### **Polyurethane**

It is polymer which consists of combination of small organic units of urethane links.

Polyurethane is selected to manufacture Mecanum wheel rollers set because it is nonflexible, high performance adhesive and a hard plastic parts: [7]. Polyurethane rollers are easy to manufacturing using dies and molds. They easily adopt the shape of the given die to manufacture rollers or required product. In its simplest form, Polyurethane is a two part material. These two parts are known as the pre-polymer and the curative. On their own, they can be stored and generally used whenever they are needed. The polyurethane used for manufacturing of Mecanum wheels is selected with hardness of 75A-80A. This polyurethane is considered as thermoplastic polymer. It is easy to manufacture and use in case of rollers.

The physical properties of polyurethane 75A are given in Table 1.4: [7].

Table 1.4 Physical Properties of Polyurethane

<b>Physical Properties</b>	<b>Units</b>	<b>Value</b>
Hardness	-	75
Tensile Strength	psi	4,600
Ultimate Elongation	%	490
Split Tear	pli	70
Resilience	%	27
Tear Abrasion 1000 cycles	-	40
Specific Gravity	kg/m <sup>3</sup>	1.22

### **ABS Material**

Acrylonitrile Butadiene Styrene commonly known as ABS is thermoplastic material. The material is manufactured by varying the concentration of styrene and acrylonitrile in presence of polybutadiene.

Some of the highlights of ABS material are given below:

- Tough, rigid, hard
- Creep resistant
- Dimensional stability
- High tensile strength and stiffness
- Very high impact strength
- Excellent high & low temperature performance
- Excellent ductility
- Chemical resistance

Table 1.5 ABS Material Properties: [8].

<b>Properties</b>	<b>Values / Units</b>
Density	0.0376 kg/m <sup>3</sup>
Melt Flow	18 – 23 g/10 min
Hardness	103 -112 (in grade)
Tensile Strength	6160 – 6500 psi
Elongation at break	23 – 25 %
Flexural Modulus	326 – 331 ksi
Flexural Yield Strength	8790 – 10600 psi
Maximum service temperature	89 <sup>0</sup> C

### **SBR Rubber**

SBR rubber is commonly used in application such as rollers. It is a mixture of Styrene and Butadiene material.

Some highlights of SBR rubber are given below:

- Excellent abrasion resistance
- Excellent adhesion to metal
- Adhesion to rigid material with excellent grip
- Good at compression
- Flex cracking resistance is good
- Excellent tear resistance
- Very good in vibration damping
- Good steam resistance

- Fair to weather exposure
- Excellent water resistance

To know more about this material its properties are given in table 1.6

Table 1.6 Properties for SBR Rubber: [8].

Properties	Values / units
Durometer / Hardness range	30 – 95 Shore A
Tensile strength length	500 – 3,000 Psi
Elongation %	450 % - 600 %
Low temperature range	-51.11 <sup>0</sup> C to -34.44 <sup>0</sup> C
Brittle point	-62.22 <sup>0</sup> C
Maximum continuous use temperature	107.2 <sup>0</sup> C

#### 2.1.6. Mecanum Plate

Current Mecanum plate consists of aluminum material. Aluminum is selected as it is strong and light in weight. It can be easily manufactured using sheet metal working and pressing operation. It is not costly when it comes for manufacturing on large scale: [8].

Detailed analysis for Mecanum plate for given pressing operation with manufacturing and assembly cost is given in DFMA analysis.

#### 2.1.7. Brass Sleeve & Bearing

Brass sleeve plays an important role in assembly of roller to Mecanum plate. The dimensions of every part is given in design parameters. These sleeves are connected to

bearing of same material and then to screws which then connect to the connector plate on Mecanum wheel. When the force is applied on rollers it passes to bearing then to brass tube and then onto Mecanum wheel: [9]. There are two brass tubes from which one is used for ABS material. The other brass tube is attached on internal connections of screw and connecting parts. The first tube is used as base on which ABS material part is applied. ABS has good adhesive properties on metal.

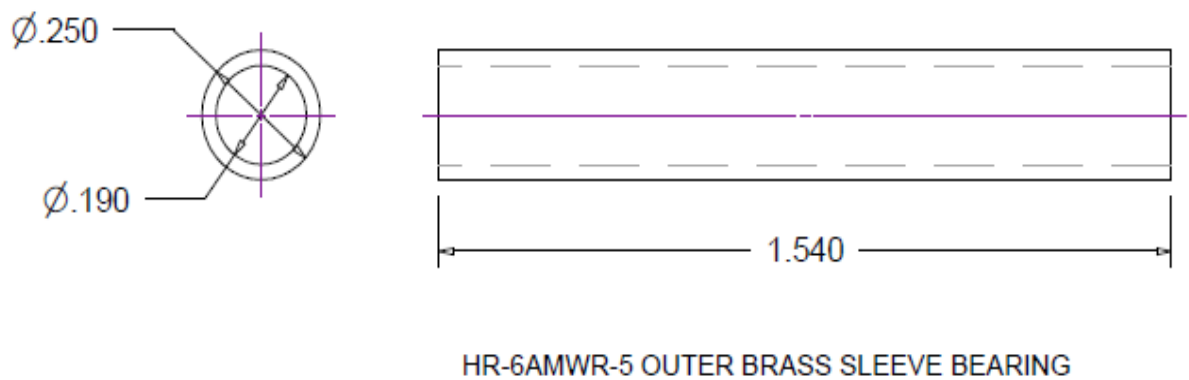
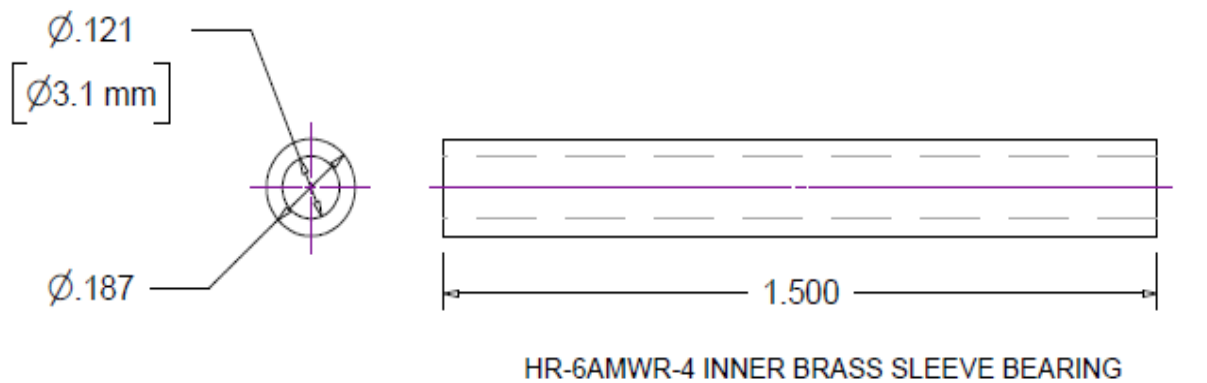

Figure 2.1 Dimensions of Brass Sleeve & Bearing: [9].

### 3. Kinematic Model

#### 3.1. Model

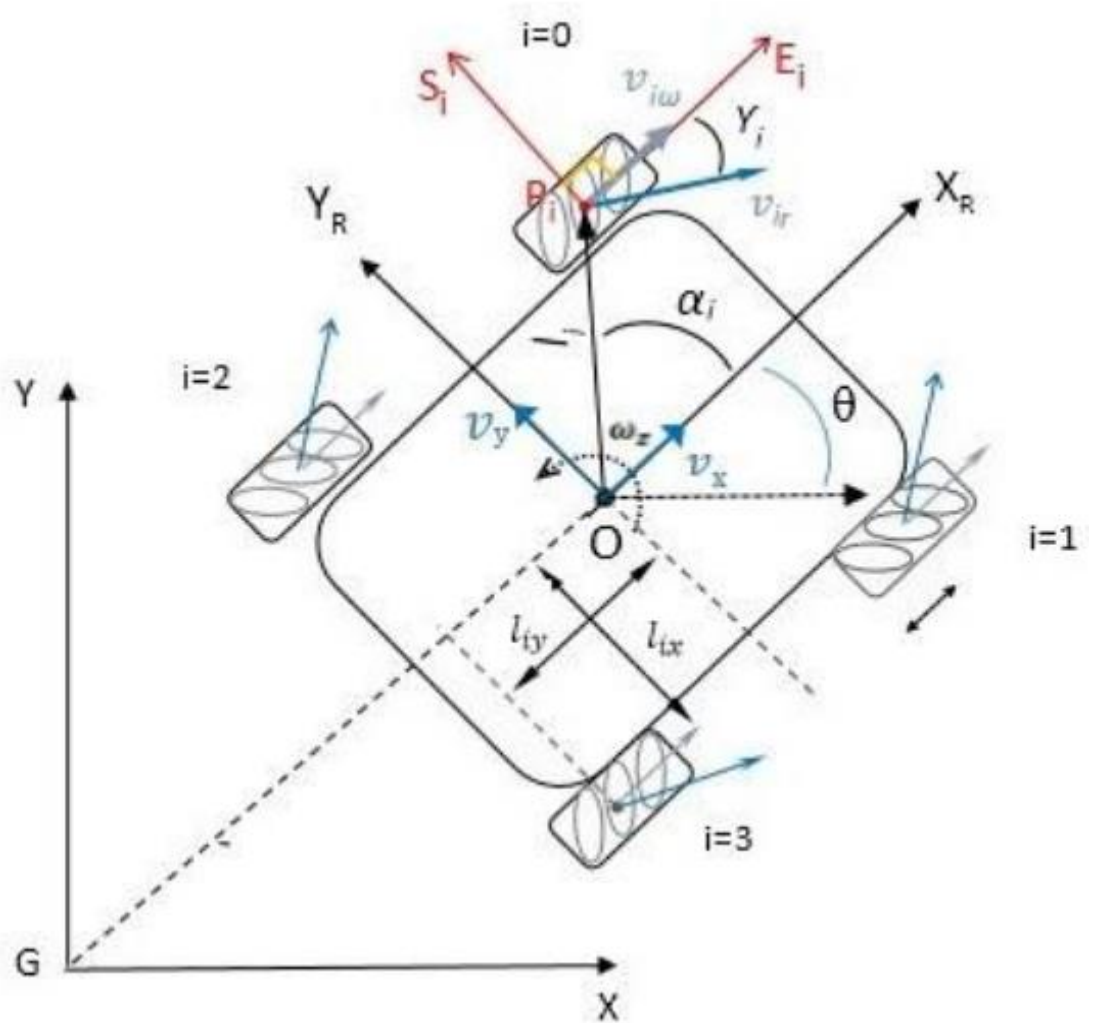

Figure 2.2 Mecanum Robot and Wheel Specification with Co-Ordinates

The parameters are given below:

- $X, y, \theta$  which gives axes and rotation angle
- $X_R, Y_R$  gives the frame which includes the system
- $S_i P_i E_i$  with wheel's center  $P_i$  these are the co-ordinate systems
- $l_{ix}, l_{iy}$  distance between wheels from center and rear wheel



- $r_i$  gives the actual radius of wheel named  $i$
- $r_r$  roller wheel radius
- $\alpha_i$  gives angle in  $OP_i$  and  $X_R$
- $\beta_i$  the given angle of  $S_i$  and  $X_R$
- $\gamma_i$  angle given in  $v_{ir}$  and  $E_i$
- $\omega_i$  angular velocity of wheels
- $v_{i0}$  [m/s] ( $i = 0,1,2,3$ )  $\in \mathbb{R}$
- $v_x, v_y$  [m/s] – linear velocity for given robotic motion
- $\omega_z$  [rad/s] – angular velocity for given robotic motion

Velocity of wheel:

$$V_{ir} = \frac{1}{\cos 45} (r^2) * (\omega * i)$$

$$V_{si} = V_{ir} * (\sin \gamma * 1)$$

$$V_{ei} = (\omega * i) * (\gamma * r) + V_{ir} \cos \gamma i$$

### 3.2. Forces

The force generated by motor drives the shaft which is connected to Mecanum wheel.

From there it goes to rollers on their axis. This force acts with some angle to plane wheel.

It is required to consider two co-ordinate system  $x$  &  $y$ : [10].

Following diagram shows the force vectors on each wheel. All the forces are distributed into  $x$  and  $y$  co-ordinate system with vector representation. The length from center of robot to the wheel is given with length '1' in mm.

The force distribution on each wheel is given in Figure 2.3.

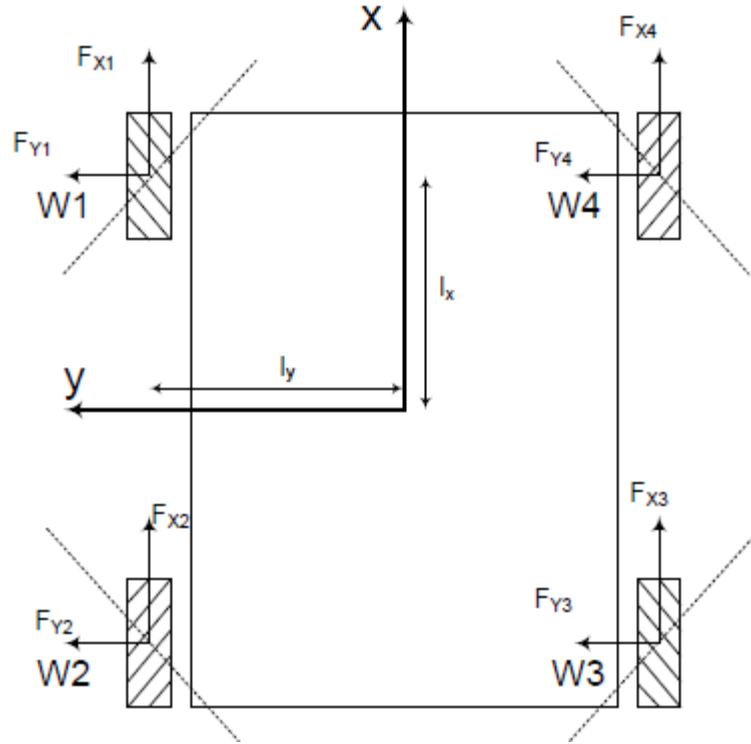

Figure 2.3 Force Distribution: [10].

The total force is divided into 2 components

$$F_{tx}i = \sum_{w=1}^4 F_{xw} i$$

$$F_{ty}j = \sum_{w=1}^4 F_{yw} j$$

Where 'i' & 'j' are unit vectors.

The rotational motion that occurs at the point (0, 0) gives torque as,

$$\tau = (-F_{x1} - F_{x2} + F_{x3} + F_{x4})l_y + (F_{y1} - F_{y2} - F_{y3} + F_{y4})l_x$$

Where  $l_x$  &  $l_y$  are radii at which forces are applied: [11].

The relation of velocity and force is given as:

$$V \propto \sum_{w=1}^4 F_w$$

### 3.3. Wheel Velocity

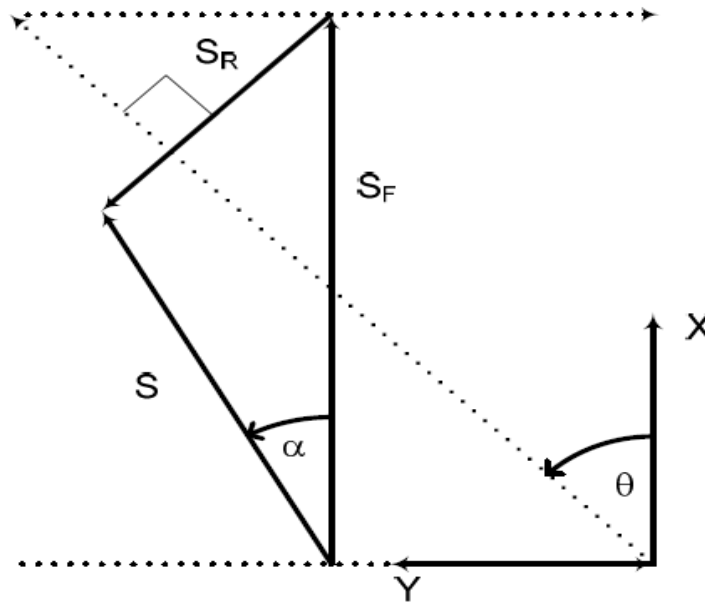

Figure 2.4 Displacement Vector: [11].

Following terms explain the vector's representation from figure 2.4

' $\alpha$ ' is the angle between two displacement vectors.

' $\theta$ ' is angle between vector profile and co-ordinate system.

$S_F$  = displacement solo due to wheel rotation.

$S_R$  = displacement due to rolling in the direction orthogonal to roller axis.

$S$  = Resultant displacement.

### 3.4. Roller Surface Geometry

Roller makes contact on surface while its motion at given single point. According to the motion of Mecanum wheel it is observed that wheel makes an elliptical profile on its surface while it covers some distance.

The point of contact and other specifications can be seen from Figure 2.5: [11].

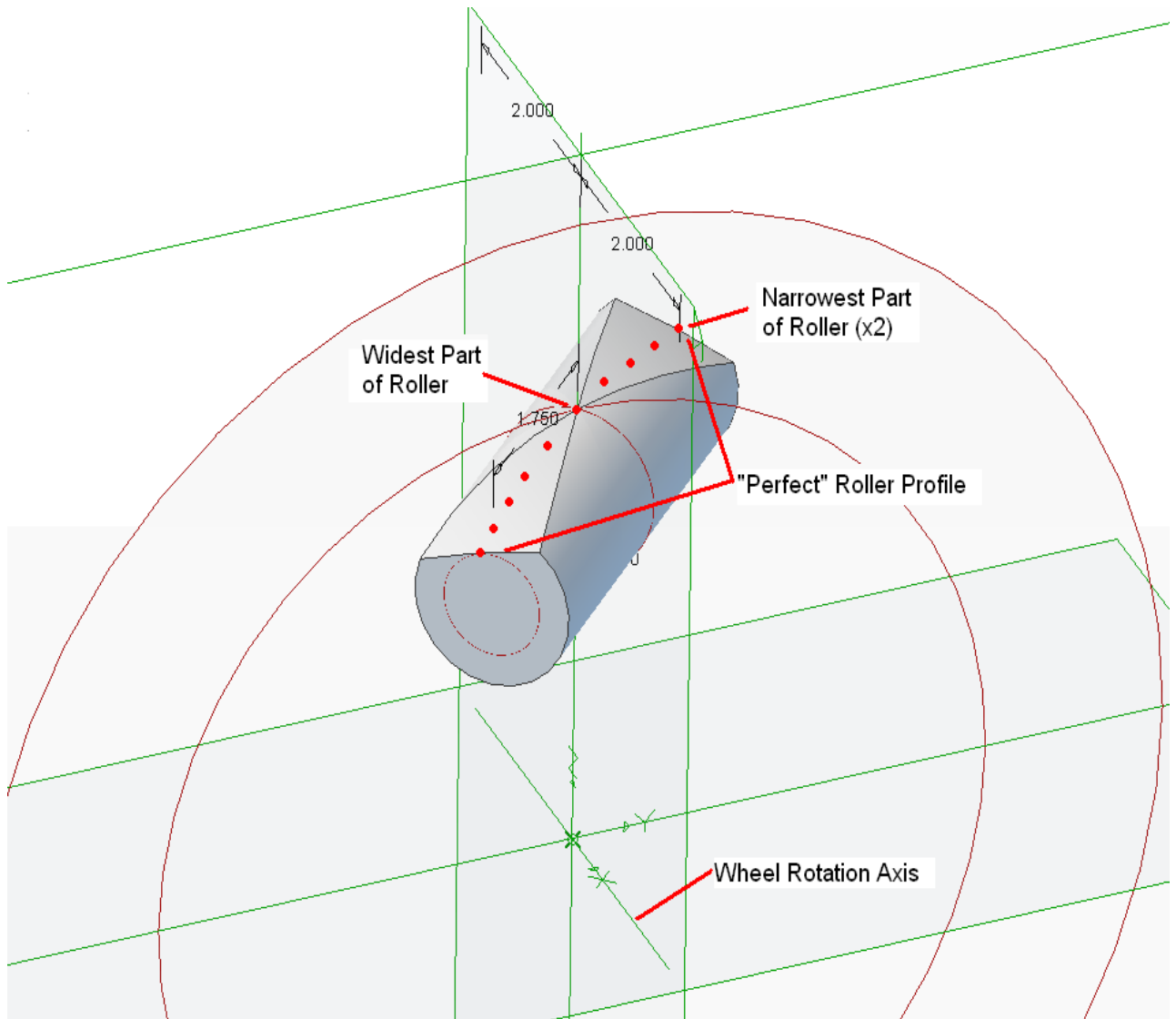

Figure 2.5 Roller Profile: [12].

Figure 2.5 shows that as widest part is the point of contact on surface and roller is at  $45^{\circ}$  to the surface it makes a curved point of contact profile on its surface. The maximum load applied to roller get of most of its impact at this given point. Red dots on roller surface are the point which touches ground while roller moves. The profile given by the red dots is not in straight line as the roller axis is  $45^{\circ}$ . At any given point we get four points of each roller touching surface below it.

## **4. Manufacturing**

### **4.1. Wheel Plate**

The wheel plate is designed by considering its strength and weight at the same time. The material considered for manufacturing of plate should be able to satisfy these two given conditions. The material selected for manufacturing plate is Aluminum. Aluminum is very good for its properties and perfect material for manufacturing of plate.

The main plus points of selecting Aluminum for manufacturing of Mecanum plate are given below:

1. Aluminum is almost 1/3<sup>rd</sup> in weight as compared with other competitive materials.
2. Aluminum is excellent corrosion and oxidation resistant.
3. Aluminum has high thermal conductivity.
4. Aluminum costs less as compared to other metals or alloys.
5. Aluminum is fairly soft and easy to mold in given shape as it is more malleable.
6. Aluminum is difficult to weld but our application does not need any kind of welding of Mecanum plate. This factor can be easily neglected.
7. Aluminum is non-magnetic material. It gives good impact on robot applications.

### **Stamping for Mecanum Plate**

The manufacturing process selected to manufacture plate is stamping. Stamping is used to manufacture parts which can be molded easily by use of die and given material. The selected material is placed between two dies and which cuts and shapes the given material into required shape.

## **4.2. Rollers**

The selected material is polyurethane, ABS and SBR rubber. Their application is to make rollers with given specific dimensions. These materials can be melted, molded and shaped depending upon required manufacturing and application. Though all rubbers does not melt but our selected material is perfect example for manufacturing of rollers by using die & mold manufacturing or extrusion manufacturing method which can be melted and molded easily.

### **Molding Operation**

Molding process is used in manufacturing of rubber or polymer applications. The hot melted material is poured through feeder into the die which is made considering the given dimensions of product. Once the material is poured into the die it is allowed to set for some time and to take the shape of the die. After the material is cooled down it is taken to polishing.

Molding operation gives the given required shape but it is not guaranteed that the outcome of molding is a final product which can be used directly. As the edges contain extra rubber or unwanted string type material on edges. This is removed before attaching roller on Mecanum wheel.

## **4.3. Brass Sleeves**

Brass is ductile. Brass sleeves are used in this application because brass is excellent corrosion resistance. The best way to manufacture brass sleeves is extrusion. Extrusion is used for metals which are easy to elongate and moldable.

## **5. Experiment to Determine the Coefficient of Friction**

### **5.1. Overview**

The experimental setup consists of series of different base conditions to obtain values of friction on Mecanum wheel rollers. Setup consists of friction calculation machine on which Mecanum wheel rollers are mounted to find coefficient of friction. The test is conducted in university's lab facility under proper safety conditions. The experiment gives both values of static friction and kinetic friction on rollers. However once the rollers are in motion only the kinetic friction is calculated. According to the law of physics the value of static friction is always more than value of kinetic friction. When any object at rest is displaced in any given direction it is necessary to apply more force to move the object from rest.

The experiment work is conducted in following order:

1. Roller attachment with machine bed
2. Application of load on roller
3. Measuring friction coefficient by use of load cells
4. Applying different conditions to find friction

The machine setup is consist of:

1. Bed of machine
2. Clamps
3. Load cell
4. Gauge

5. Rollers (from Mecanum wheels)
6. Attachments from clamp to rollers
7. Fixtures
8. Dynamometer
9. Tribometer

The setup consist of machine unit which is capable of taking load to maximum value of 454 kg. The purpose of this experiment is to find values of roller's coefficient of friction from the range of 0.4535 kg to 68 kg in all considered conditions. Following conditions are selected for the experiment as all the conditions are applicable in actual working of robotic vehicle. If the robot is used in industry or navy ship where it climbs on iron walls, these conditions will give the most suitable C.O.F values.

The test is conducted to find out friction coefficient in conditions as:

1. Friction on concrete surface
2. Friction on aluminum
3. Friction on wet surface (on water)
4. Friction on wooden surface
5. Friction on painted surface
6. Friction on ice
7. Friction on hot surface (65.55° C)
8. Friction on greasy surface
9. Friction on sand paper with grit – 220



### 5.1.1. Experiment Process

- The rollers have sub-assembly of inner bearing, screw and washer on both ends and covered with polyurethane and ABS material on top of all.
- When considered to calculate friction on separate roller it is important to consider the way force gets applied to the roller.
- The wheel consists of 16 slots with 16 rollers on it. The position of rollers is such that it makes 45 degrees angle with surface where they touch the wheel.
- While attaching the roller on experimental setup it is important to make sure that the roller comes in exact same position as on an actual robot when it is in motion.
- The roller is then attached to the external setup which then connects to connecting bar. This connecting bar continues till it gets attached to the bottom of the clamp where the machine is going to apply pressure.
- The connecting bar works such as it will rotate the wheel on the bed of machine. The rollers will rotate on work bench without any external force acting on them.
- Due to the setup the acted force will be applied on roller by connecting bar.
- After making sure that the connection is correct, action is taken to calibrate the machine so that the initial force applied on roller is zero.
- Once the setup is completed the experiment can be conducted step by step.
- The machine is capable of reading the friction and give the result on display bar.
- The coefficient of friction is given as kinetic friction.
- Includes load cell in machine itself.
- The load cell gives the average load applied on the part.

### 5.1.2. Machine Specification

Table 1.7 Friction Tester Specification

<b>Bed Length</b>	650 mm
<b>Bed Width</b>	350 mm
<b>Span Adjustment</b>	10 -160 mm
<b>Force (max)</b>	1000 N
<b>Speed Accuracy</b>	+/- 0.2% of selected speed
<b>Supply Voltage (+/- 10%)</b>	115VAC/230VAC
<b>Max Power Required</b>	150VA

#### **Load Cell**

Load cell is a device which is used to calculate the strain value applied on it. It measures the applied load and gives magnified output value of applied force. It works on contraction and expansion base where small amount of variation is detected.

#### **Tribometer**

Tribometer is used to find the value of coefficient of friction, wear and tear between two contacting surfaces. The principle used in Tribometer is application of mass until the object start to move. In case study it is observed that the coefficient of friction is the ratio of two masses.

#### **Coefficient of Friction**

Traction of roller on the Mecanum wheel is given by equation,  $\mu \times P$

Where,  $\mu$  is the coefficient of friction for polyurethane roller and track of contacting surface and P is the load on roller.



Figure 2.6 Tools for Experiment



Figure 2.7 Roller with Attachment for Experiment



Figure 2.8. Mecanum Wheel of 6"



Figure 2.9. Mecanum Wheel of 9"

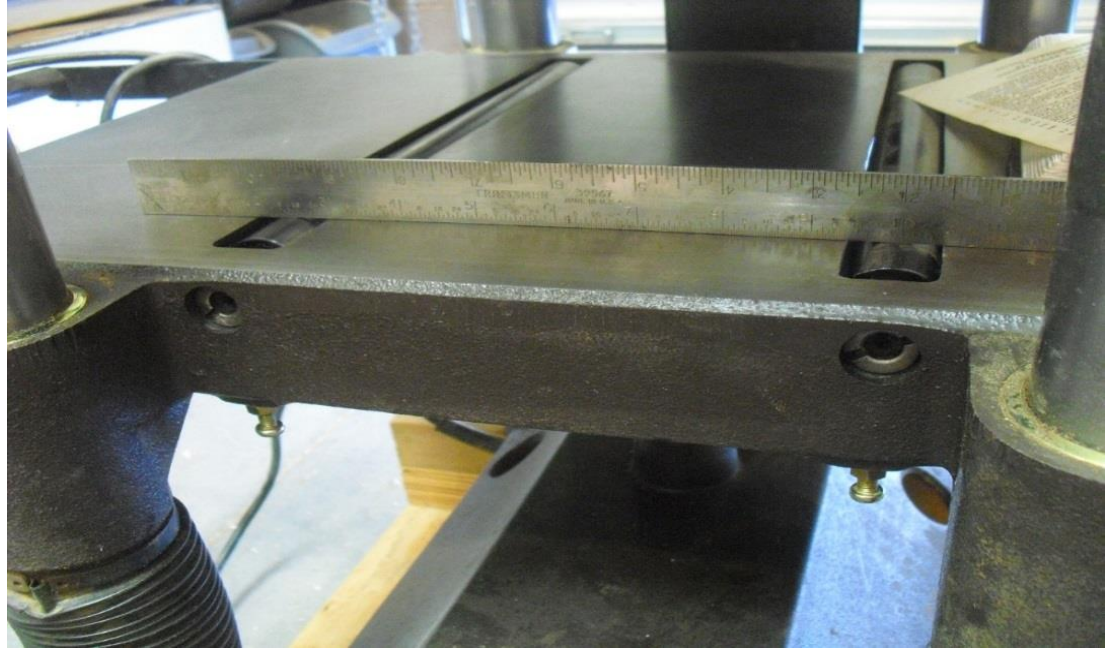

Figure 3.0 Surface Bed to Calculate C.O.F

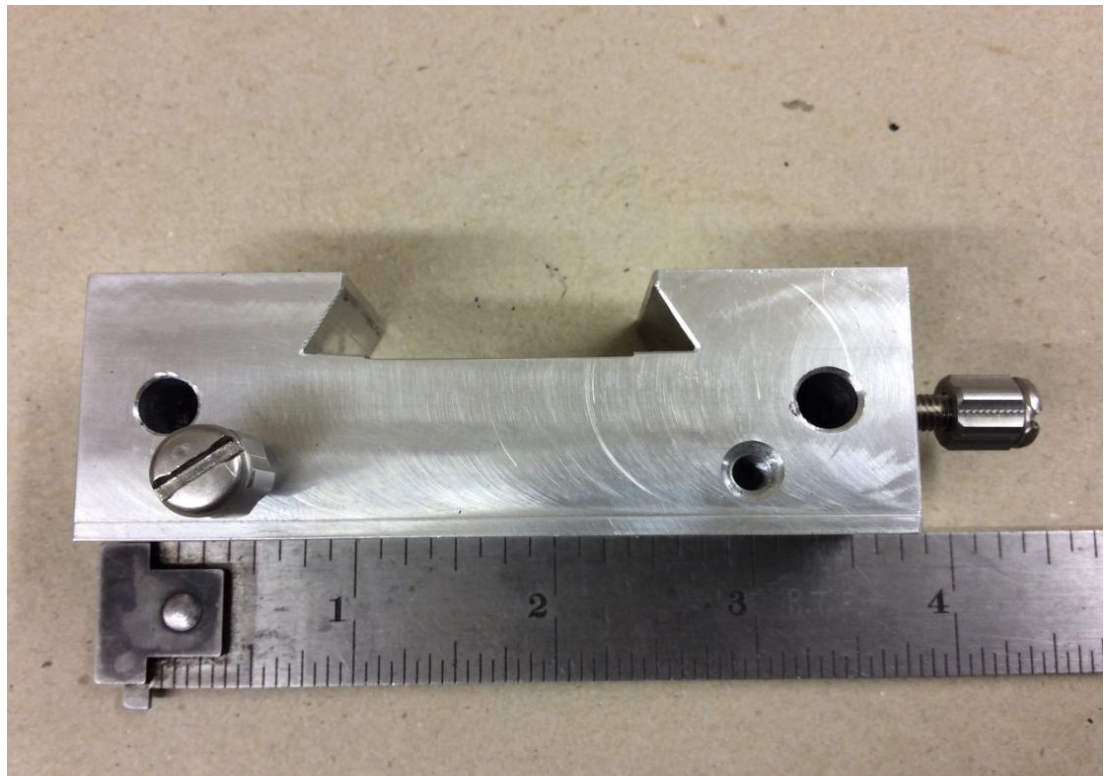

Figure 3.1 Experiment Tool for Length Measurement

### 5.1.3. Case 1 - Coefficient of Friction on Concrete Base

The case is studied for polyurethane wheel on rough concrete surface. Concrete is a very strong material which gives wheel or rollers a good grip on it. This case is considered if roller is moving on a concrete for a while for transporting.

Mecanum wheel is made up of polyurethane material which will get excellent grip on concrete surface as concrete has rough surface of contact. To overcome this friction force, Mecanum wheel needs more driving force as a result, there will be more friction.

The experiment is conducted on test bed to find the value of frictional coefficient between these two surfaces. The test is taken from 0.4535 kg to 68.03 kg. The result of test is given in Figure 3.2.

All the values in chart are calculated for kinetic friction as roller was moving on machine bed.

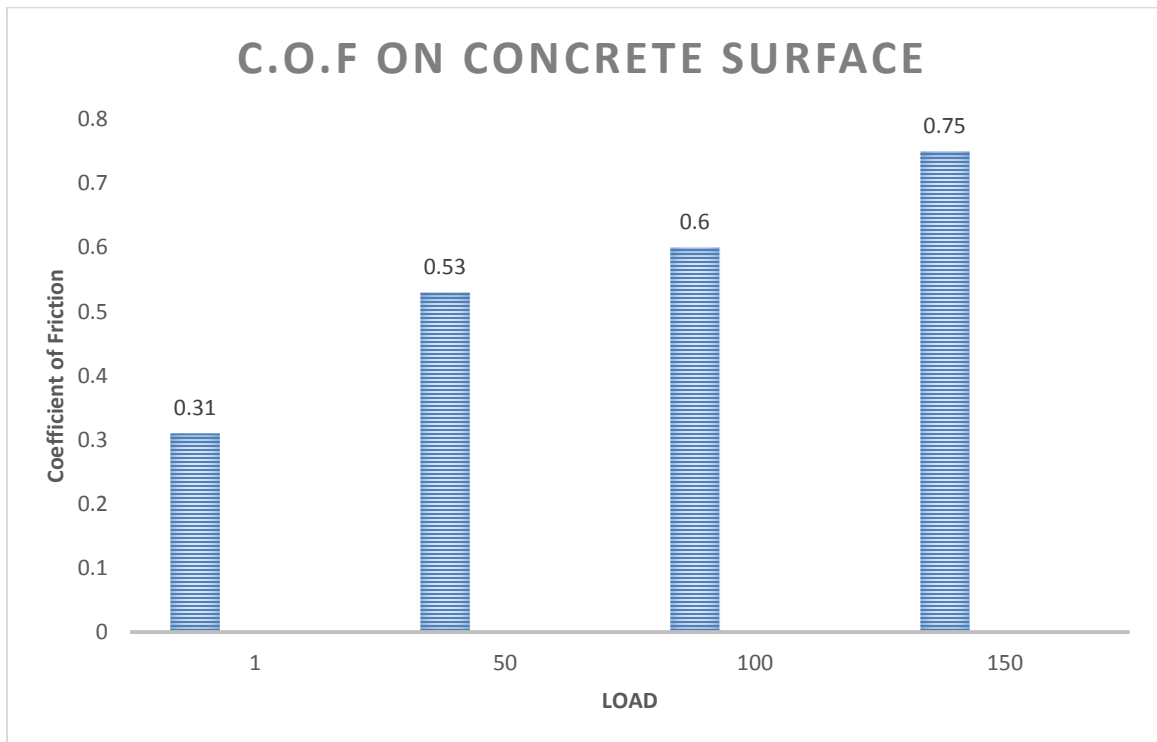

Figure 3.2 Coefficient of Friction on Concrete Surface

#### 5.1.4. Case 2 - Coefficient of Friction on Aluminum Plate

Aluminum metal comes in different composite forms. This test is conducted for the regular aluminum sheet which does not include any other material as composite with aluminum. Aluminum is used for various applications like cans, frames, foils, airplane parts. Aluminum is excellent corrosive resistant and it is non-magnetic. Aluminum surface is rough as seen under microscope. Its surface contains peaks and valleys which make it good on friction part.

Properties of Aluminum:

Melting point –  $660.2^{\circ}\text{C}$

Boiling point –  $2480^{\circ}\text{C}$

Thermal conductivity –  $0.57 \text{ cal/g.}^{\circ}\text{C}$

Density –  $2.6898 \text{ g/cm}^3$

Modulus of elasticity –  $68.3 \text{ GPa}$ .

Aluminum frame was taken and fixed with precaution in the fixture to ensure that there are no loose parts while experiment is being conducted. If aluminum is kept in fixture with no proper tightening of the test bed, there will be an error.

The experiment is conducted on aluminum plate with 3 different sets of readings. The final value of C.O.F on aluminum plate is average of all the readings. The purpose behind it is to get the most accurate value. Same roller is used to find all sets of readings because; the same rollers set will be used again and again.

The graphical representation of final result is given in Figure 3.3.

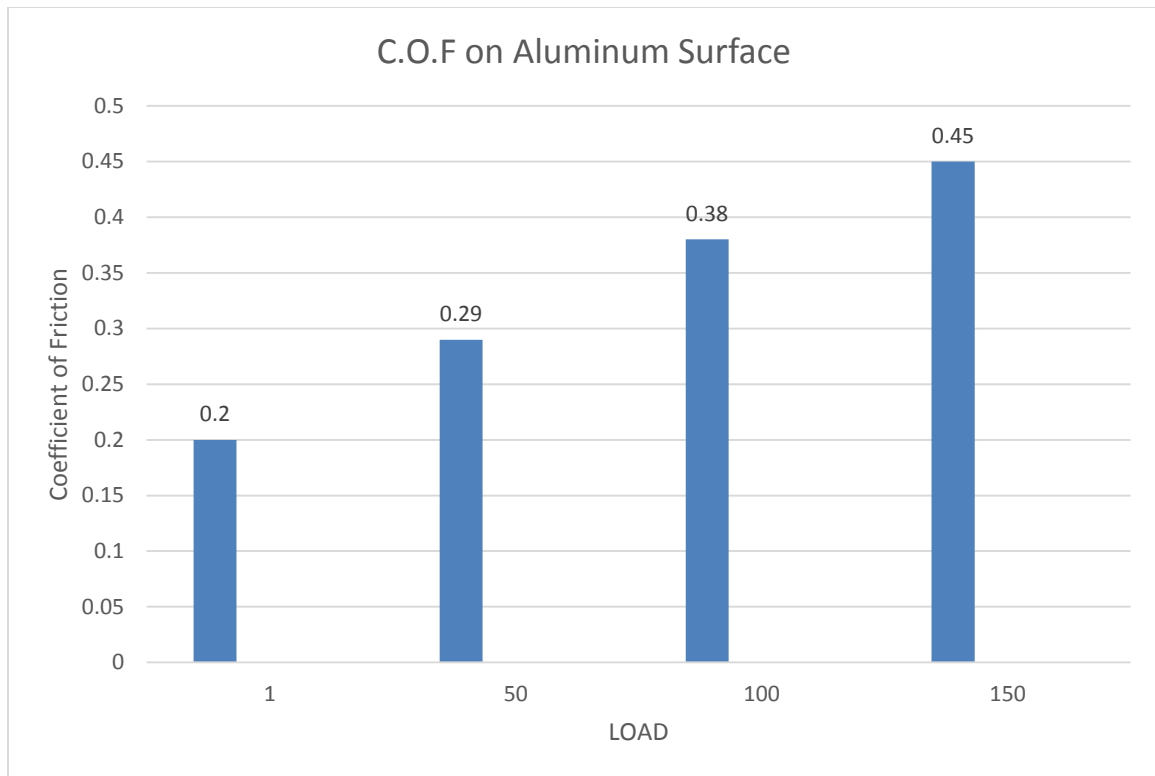

Figure 3.3 Coefficient of Friction on Aluminum

#### 5.1.5. Case 3 - Coefficient of Friction on Wet Surface

The experiment is carried out by applying water on the test bed. The addition of water makes the surface skiddy. In terms of friction, as the surface is more slippery there will be less friction between two surfaces. This test is important as Mecanum wheels can be used in outside environment where rollers will directly come in contact with water and as the robot will move through the wet surface, it should have good grip so that if robot needs to stop abruptly, it will be possible to apply quick stop.

This test is rated amongst the most important one as rollers can come in contact with water on regular basis. If the robot is used on submarine's outer surface for any special purpose task, these values play important role in it. The graphical representation of the test result is shown in Figure 3.4.



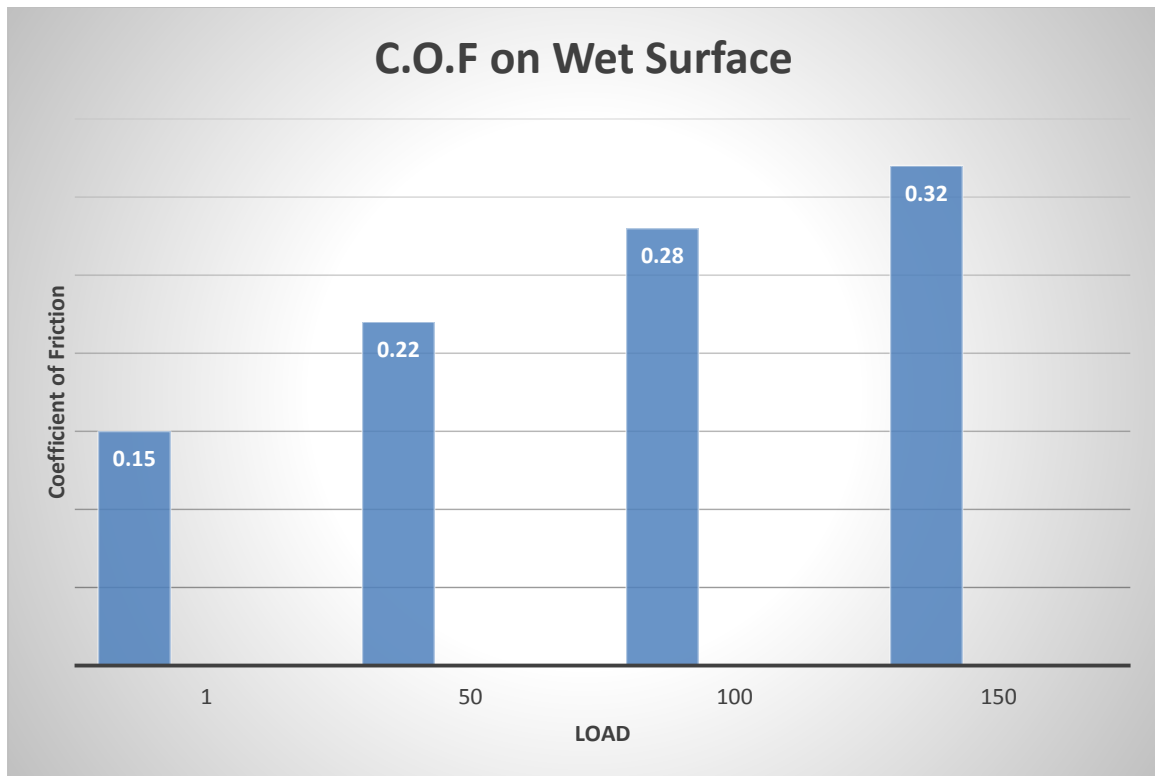

Figure 3.4 Coefficient of Friction on Wet Surface

#### 5.1.6. Case 4 - Coefficient of Friction on Finished Wooden Plate

The experiment for finding friction on wooden plate, the plate is polished by using sand paper to make the surface even. Making the surface straight and even helps to calculate actual C.O.F.

The plate used in this case is 60 mm × 75 mm which is mounted on the fixture. The thickness of plate is kept as 10 mm. If we consider plate with thickness less than 10 mm, it may fail when a force of more than 68.03 kg is applied. This test is performed with consideration of robot working in forest area and it has to cover specific distance through woods.

The resulted graph for C.O.F values in case of wooden surface are given in Figure 3.5.

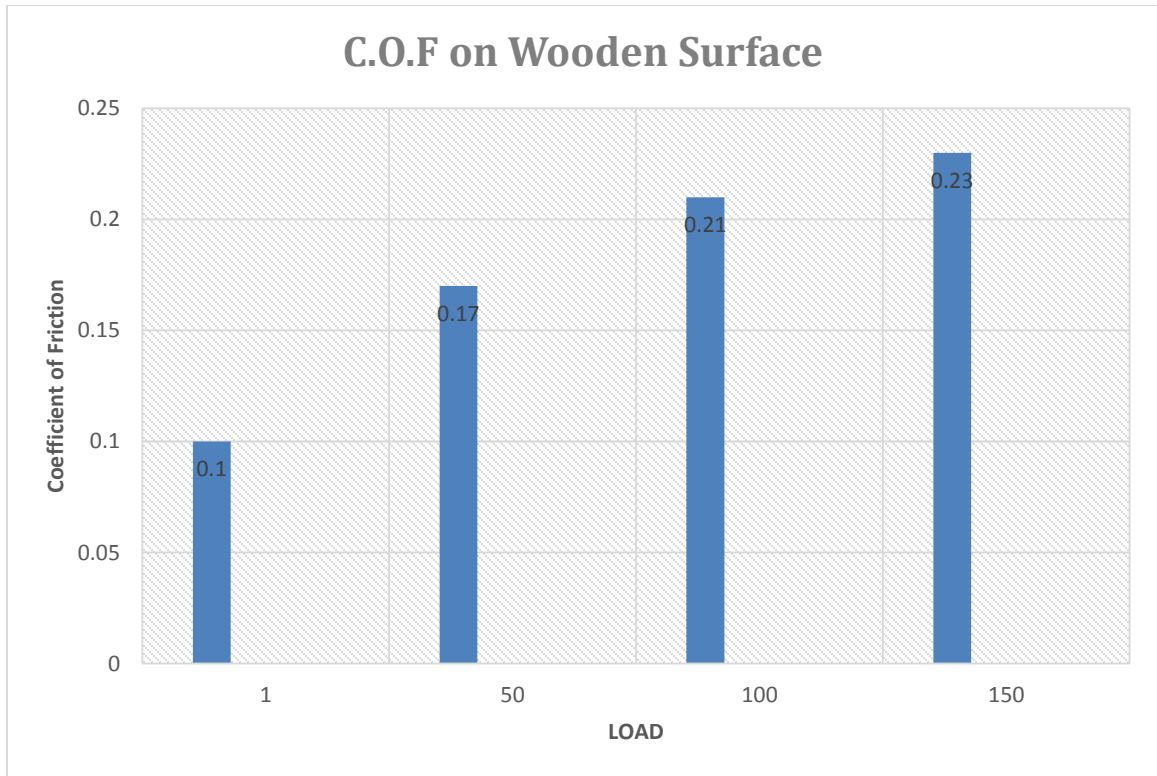

Figure 3.5 Coefficient of Friction on Wooden Surface

#### 5.1.7. Case 5 - Coefficient Friction on Painted Surface

The experiment is conducted by using a metal frame with spray painting on its surface.

The name of paint used for this experiment is 'Rust-oleum umber spray'. The purpose of selecting this paint is given with specifications.

- This color is rich in finish.
- It is great on wood or metal surface as it gets equally spread on both surfaces.
- It does not cause fatigue on surface which serves great purpose on larger load of 68.03 kg.
- This paint is durable and corrosion resistant with high end looks.
- It costs less than \$8 per bottle.

The graphical representation of C.O.F for painted surface is given in Figure 3.6.

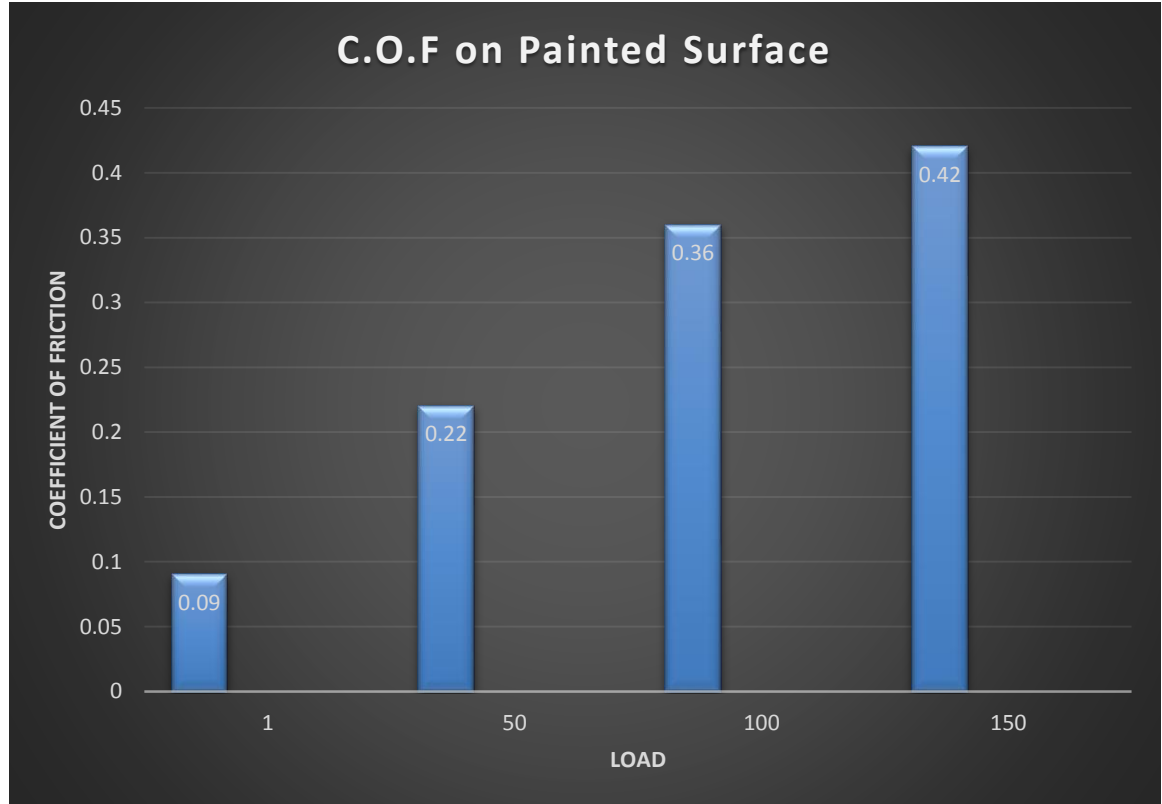

Figure 3.6 Coefficient of Friction on Painted Surface

#### 5.1.8. Case 6 - Coefficient of Friction on Ice

This experimental test is little different than other tests. The base surface used to find C.O.F is ice. Ice is considered to be very slippery with very less traction. The term traction explains that the contacting area of rollers and ice do not give friction as we got in the case of concrete or metal surfaces. The area of ice keeps changing its top surface form all the time because of atmospheric temperature. The ice form used in the test is different than ice on which roller will be actually used. The difference is that, the ice on which the roller will move is not the same ice as experimental. The value of coefficient of friction in case of actual working of robot will change. While testing coefficient of friction value, ice was melting constantly making it difficult to take reading. To conduct

this part of the experiment, trial and error method of verification was used to find the actual C.O.F value.

Some of the initial difficulties faced are mentioned in following list:

- Difficulty in holding the ice cube on bed of the machine.
- Maintaining the ice cube location at the same place.
- Keeping the maximum thickness of ice cube more than 10 mm so that it will not break under high loads.
- Keeping the room temperature under normal room temperature to prevent ice from melting.
- Keeping roller dry for different set of reading in trial and error method.
- Avoiding the contact of ice with other materials.
- In situation like ice coming in contact with oil or grease, it will change the value of coefficient of friction on ice.
- Real time values of C.O.F on ice are far different than experimental values as the ice form in real time is not in solid shape. It comes as small crushed dust like particles.
- Working condition of rollers on icy surface can be considered as extreme because; the main factor which is evaluated in the experiment is coefficient of friction and ice has the lowest friction value with roller as it is seen in the experimental results.
- To overcome this problem, the roller surface needs to be given some gripping design or screw mounting on its surface.

The aggregate value of C.O.F on ice is provided in Figure 3.7.

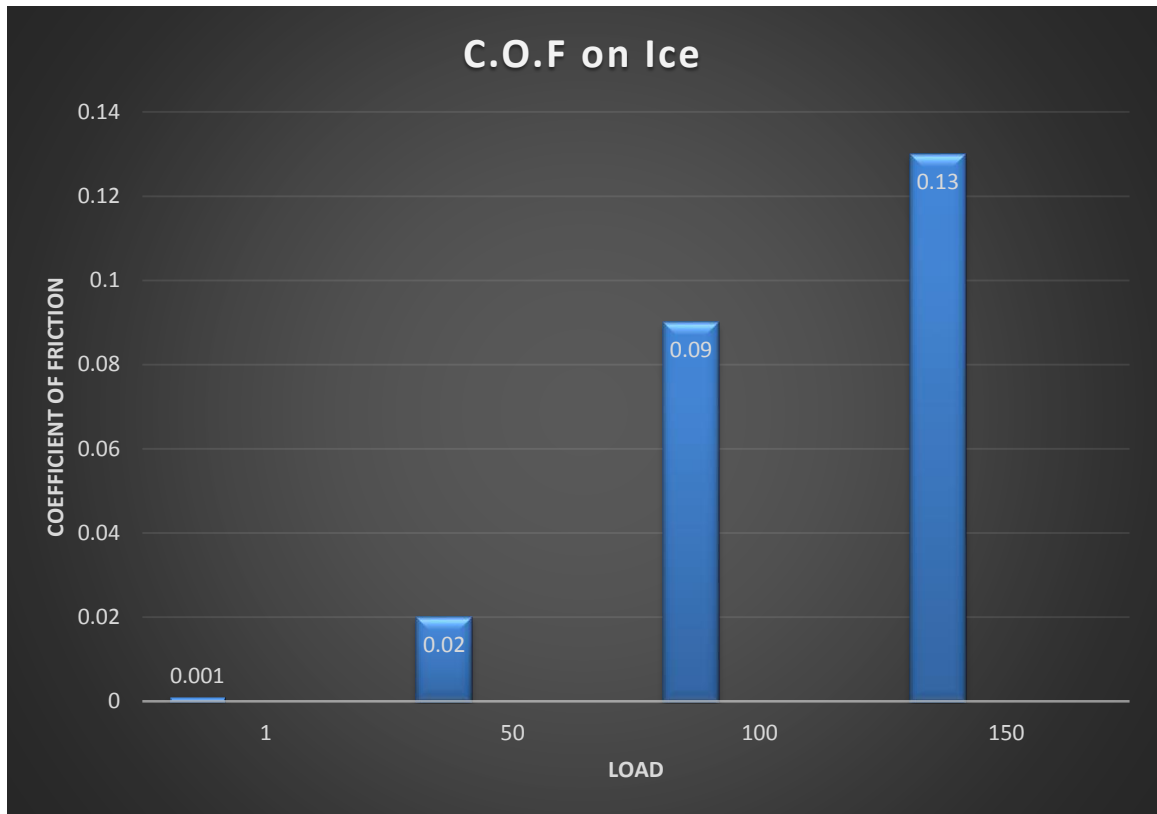

Figure 3.7 Coefficient of Friction on Ice Surface

#### 5.1.9. Case 7 - Coefficient of Friction on Hot Surface

The experiment of testing rollers in high temperature is very useful as the Mecanum wheel robot may operate in desert area for given task. It makes this experiment very important for C.O.F values. The experiment is conducted on ceramic plate which was kept at the temperature of  $65.55^{\circ}\text{C}$ . To ensure that plate is at  $65.55^{\circ}\text{C}$ , the temperature sensors were used which indicated current temperature of ceramic plate at given interval. As ceramic plate is taken for this experiment, the surface of ceramic plate also interferes on the C.O.F values. Ceramic surfaces are usually rough on outside. As the roughness increases, the value of C.O.F also increases giving a good grip for Mecanum wheels.

The values of C.O.F for hot surface are given in Figure 3.8.

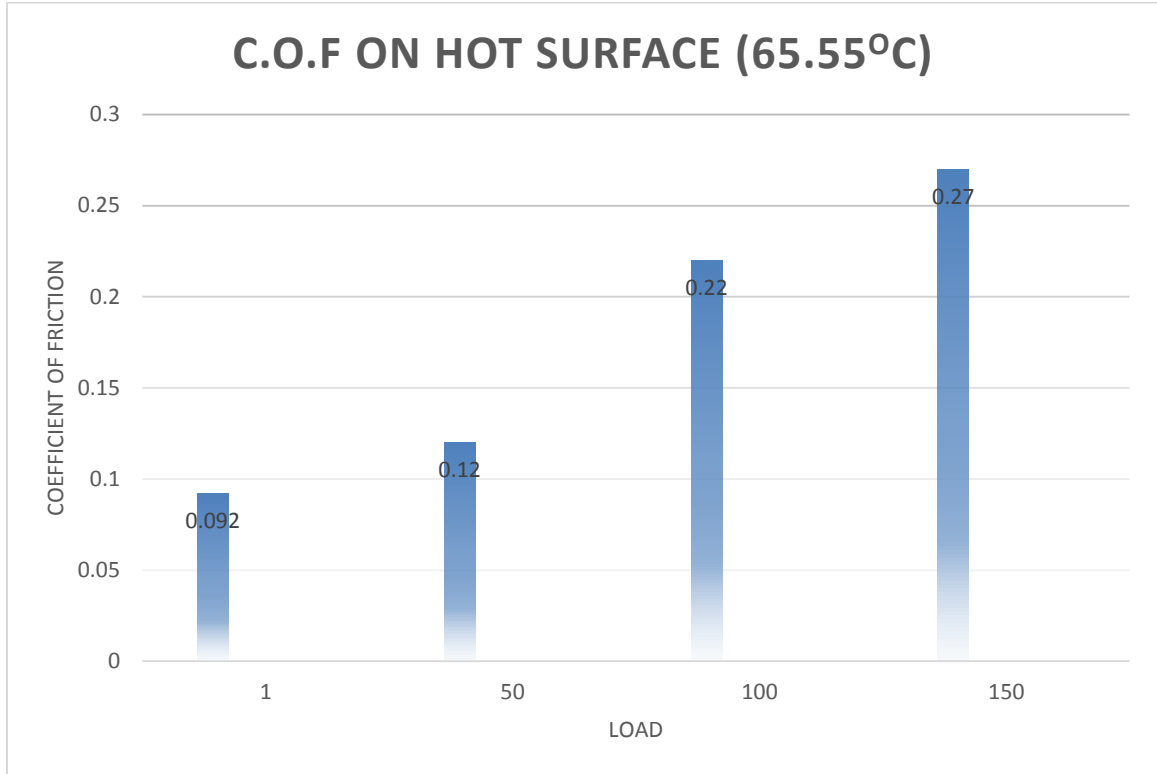

Figure 3.8 Coefficient of Friction for Hot Surface at 65.55°C

#### 5.1.10. Case 8 - Coefficient of Friction on Greasy Surface

The experiment is conducted with covering the bed of the machine with grease. Addition of grease to the surface makes it extremely slippery. If the surface is more slippery, less will be the coefficient of friction.

The results of this case study are compared with the case of ice and grease, in both cases the surface area in contact with roller makes the friction very negligible. If the roller is carrying heavy load of 90.71 kg it will make it difficult for the robot to operate. For the solution, it is required to consider other roller material or increase the grip on roller by making few changes on its outer surface.

The graphical representation of these values are shown in Figure 3.9.

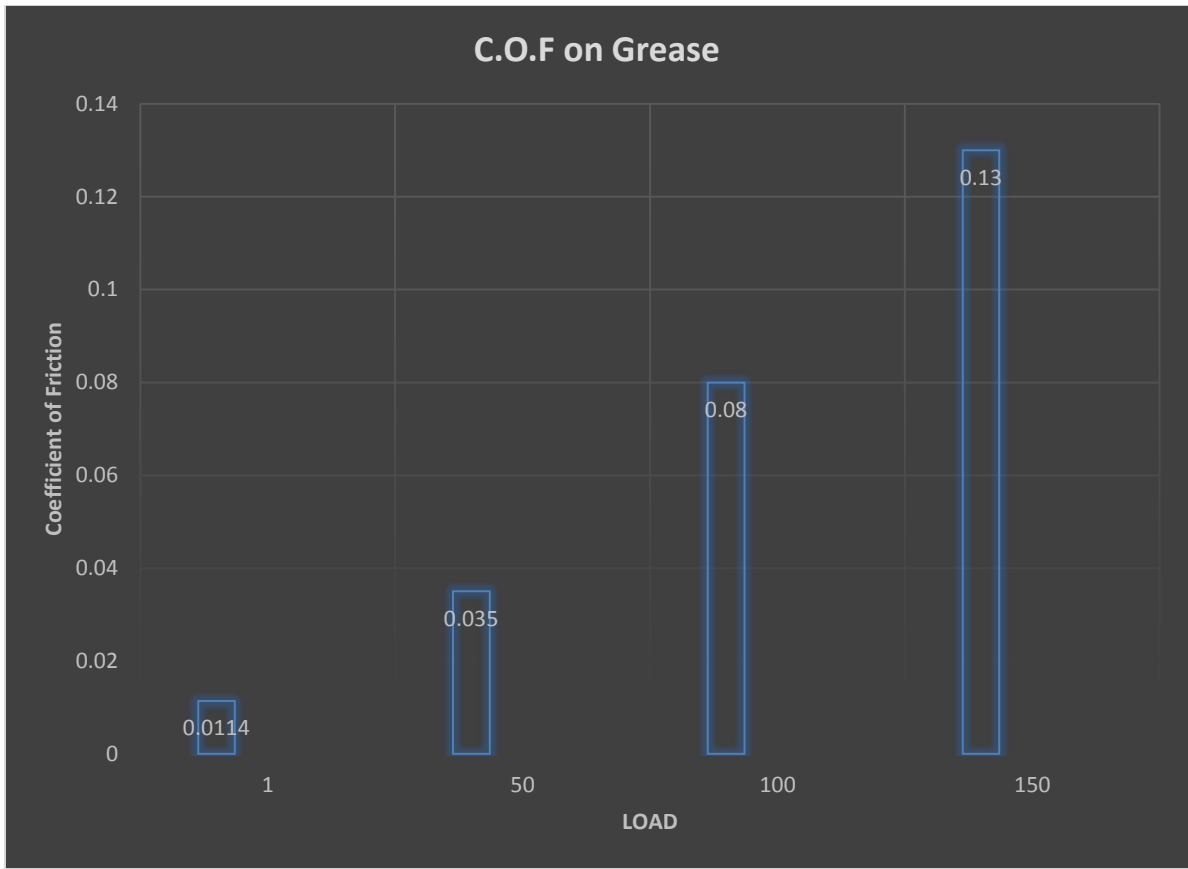

Figure 3.9 Coefficient of Friction on Greasy Surface

#### 5.1.11. Case 9 - Coefficient of Friction of Rollers on Sand Paper with Grit-220

This case study elaborates more on the contact between polymer material and rough sand paper. Sand paper comes in different surface finishes according to its use. Superfine sand paper is used for polishing purpose. Sand paper grit ranges between 40– 600.

The different sand papers are shown in Figure 4.0 and Figure 4.1. Grit 40 is rough while grit 600 is extremely polished.



Figure 4.0 Sandpaper with Grit-40: [13].



Figure 4.1 Sandpaper with Grit-600: [13].



The obtained values of C.O.F on sand paper are represented in Figure 4.2.

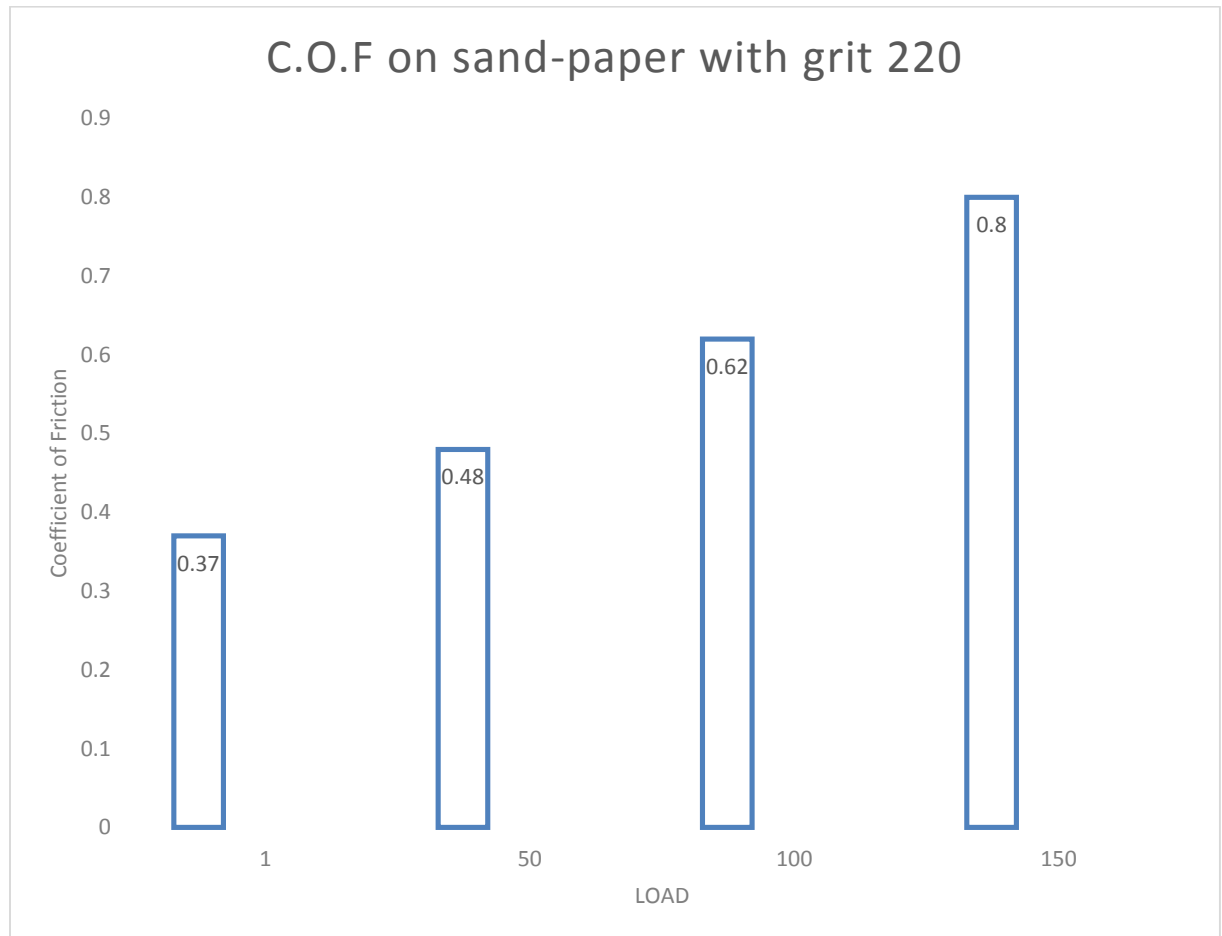

Figure 4.2 Coefficient of Friction on Sand Paper with Grit - 220

Figure 4.2 shows high values of C.O.F by using concrete, metal and sand paper. The purpose of using material with high roughness is to observe wear and tear of rollers. As 64 rollers roll at given specific time when Mecanum wheel robot moves, it is very important to see the life span of the rollers and factors affecting its performance.

To determine the life span of polyurethane rollers, different environmental conditions are tested to verify results.

To explain the behavior of friction, following chart is given which compares friction values with increase or decrease of given factors in chart.

Table 1.8 Important Friction Factor: [14].

To increase friction	Factor	To decrease friction
Increase	Unit load	Decrease
Increase	Surface finish	Decrease
Decrease	Speed of motion	Increase
Increase	Pressure	Decrease
Omit	Lubrication	Use
Decrease	Temperature	Increase

To ensure that the experimental results are correct, it is important to verify the values of  $\mu$  with previous experimental values.

Following table shows the result compared with actual values of coefficient of friction with given condition.

Table 1.9 Friction Value Comparison

Material Base	Coefficient of Friction Calculated in Experiment (average)	Given Coefficient of Friction by Previous Experiments
Concrete	0.65	0.71
Aluminum	0.40	0.45
Wet Surface	0.30	0.34
Wooden Surface	0.21	0.29
Painted Surface	0.35	0.30
Ice	0.08	0.059
Hot Surface (65.55°C)	0.19	0.15
Grease	0.06	0.010
Sand Paper	0.67	0.75

## **6. Mecanum Wheel Life Span**

Polyurethane is one of the best polymers that can be used for production of rollers because of its properties. The way to produce such wheels using mechanical manufacturing process is either casting or molding. Molding process is efficient & more practical than casting for manufacturing of rollers: [14]. Molding consists of injection of melted material, in which given hot melted polymer is poured through a given feeder area into the mold and kept to settle for some time. It gets the shape of the mold as it cools down. The inner face of roller consists of ABS material which is thin layer between polyurethane and bearing. The ABS polymer acts as adhesive which binds polyurethane and bearing so they never slip on each other's surface. ABS is categorized under thermoplastics: [14].

Some important properties of ABS polymer:

- High impact resistance
- Toughness factor is high
- Doesn't peel off at extreme low or high temperature

### **6.1.Side Peel of Rollers**

Material selection and friction test are important factors to be considered for the working of rollers. The other important factor to be considered is side peel test of roller material: [15]. Side peel test of roller can be explained as the wear and tear of material that occurs under high load or temperature.

The experiment is conducted on peel tester experimental setup to obtain constant friction between roller's side edges and the machine on which it is tested.

### 6.1.1. **Theory for Side Peel Effect**

- The machine used to find the side wear and tear of roller consists of test bed, vertical loading unit and clamps.
- The roller is fixed in clamp such that the roller axis is exactly perpendicular to the test bed.
- It is ensured that the complete edge of roller touches the setup to take correct values.
- The roller is then constantly contacted by rotational motion with constant application of force on it from vertically mounted load unit.
- The value of load is gradually increases from 0.45 kg to 68.03 kg.

### 6.1.2. **Observations & Results**

According to the test, the material starts to peel out when load reaches its maximum value of 68.03 kg considering that the wheel is continuously tested for 1 hour with the maximum load. The tested specimen roller start to show wear on its edges when the roller's surface reaches its highest temperature range after which the material fails to perform.

Main problem observed in test was that the adhesiveness or bonding between polymer and bearing is not sufficient. To improve the process and reduce the early peeling of material from roller and to increase strength of roller, following suggestions are given.

Figure 4.3 shows the roller's surface after it has been tested for peeling effect in condition of high load and change in temperature.

The material starts to peel after 1 hour of continuous rubbing with surface which suggests that if roller is working in a hot environment and running over surface with maximum friction like cement, it will damage the roller's surface quickly.



Figure 4.3 Wearing of Roller

Given suggestions to reduce wear and tear for roller:

- 1) Design the roller's edges such that the point of contact of roller's edge will never touch the ground to avoid the chance of side peel effect.
- 2) The addition of adhesive material between polymer and bearing to make both surfaces stick to each other more firmly and to make the roller strong for its overall performance in such extreme working conditions.

## **7. Design for Manufacturing and Assembly**

The manufacturing of the Mecanum wheel is done with following norms to calculate total estimated cost for manufacturing and assembly. To find out the cost for manufacturing and assembly, the design of complete Mecanum wheel is imported into DFMA software. First software estimates Design for Manufacturing values and the other software estimates the Design for Assembly values.

DFMA software includes license that can be downloaded from authorized website. It can take design input from most of the leading software such as CATIA, ANSYS, SolidWorks and AUTOCAD.

### **7.1.DFM**

Design for Manufacturing software deals with the way a part that can be manufactured. It is used to calculate the material dimension, process to be used to find out best machining operation to manufacture that part and the remaining additional costs that are related to it. DFM software takes the input from user and analyzes the output based on its coding.

The output values by use of DFM software can calculate cost which are close to 85% of the actual cost. Use of DFM software is beneficial as it gives all required data without even the manufacturing part initially.

DFM can take input from CAD based design software. The other way to use this software is that user should know the largest dimension of given part. DFM software is built with manufacturing processes and material selection over a wide range. Importantly, the software calculates all hidden costs and expenditures which are used while manufacturing a given part.

The user interface of DFM software is shown in Figure 4.4.

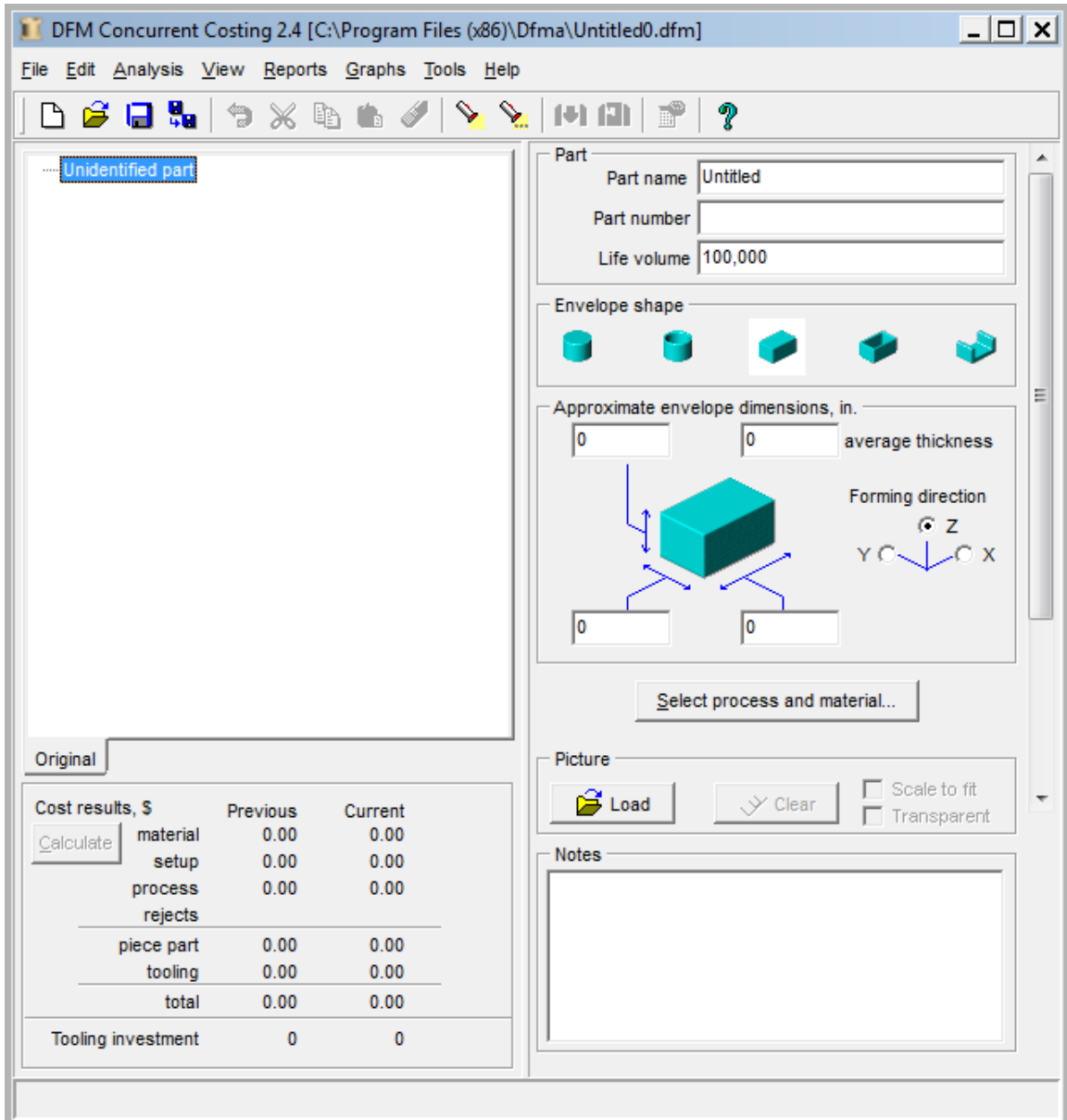

Figure 4.4 User Interface of DFM Software

The four stages in DFM software:

1. Part
2. Envelope shape
3. Approximate envelope dimensions
4. Select process and material

## **Part**

This portion consists of input parameters where user needs to add part name and life volume of that part.

## **Envelope Shape**

Envelope shape can be hollow or solid, circular or spherical and cubical or rectangular.

The given part can be any combination from above mentioned shapes. Depending upon the part selected it takes those dimensions into input parameters of DFM software.

## **Approximate Envelope Dimensions**

Approximate dimensions are the most outer dimensions of the part which decides the boundary of part. In case of cylindrical shape, it is required to put diameter and total height as parameter. If same cylinder is used as hollow part, it will ask for thickness of cylinder as well. This is done to select proper amount of material area that is required in manufacturing.

## **Select Process & Material**

This is the most important stage in DFM analysis. This process gives all the possible manufacturing or machining operation's list and the material for those machining processes.

For example, if it is required to produce a part made of aluminum, the user can go to process and material selection window and select either process first or material.

Once user select extrusion as the process it will highlight only those materials which are suitable for the extrusion processes. It is shown in Figure 4.5.



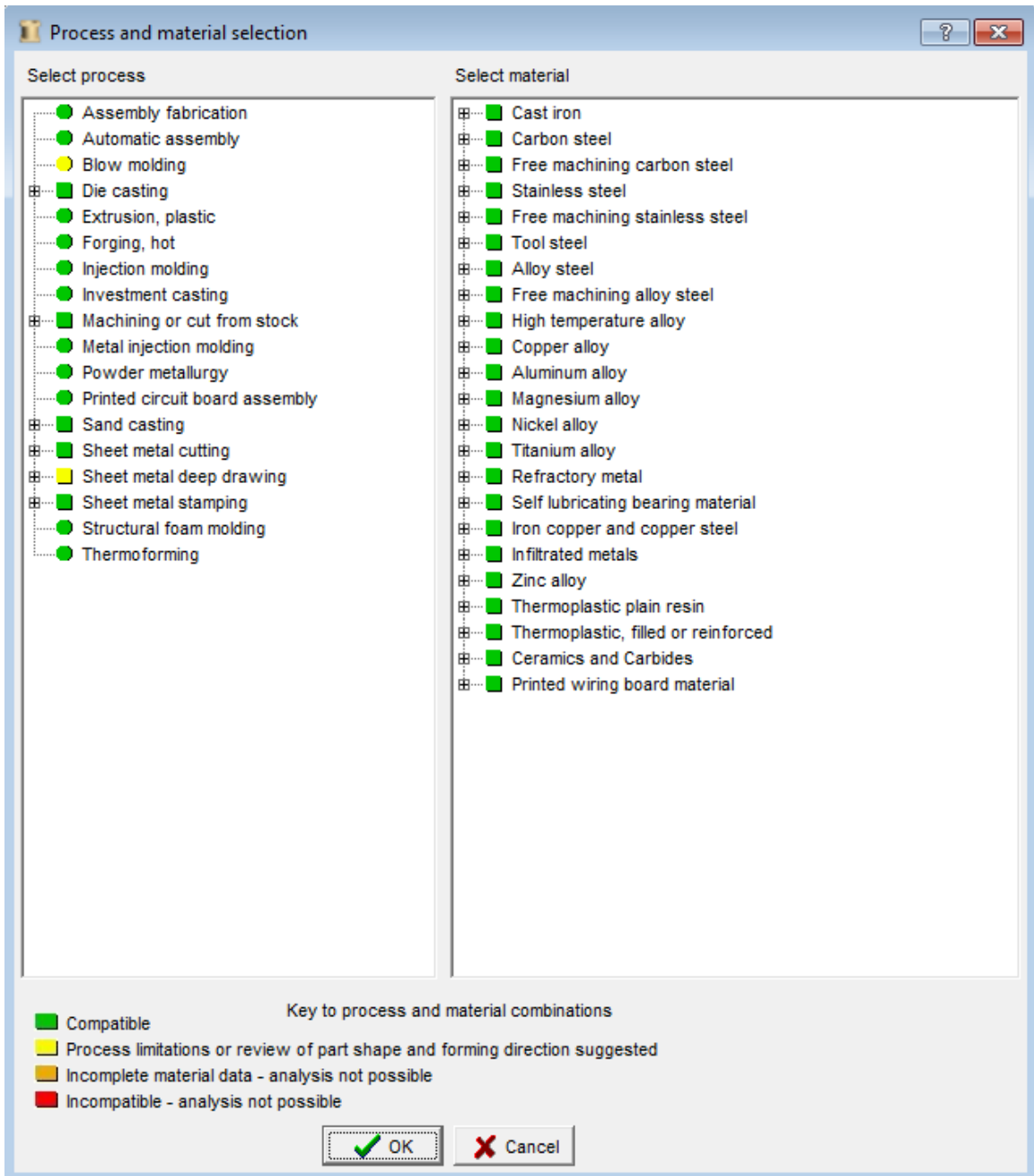

Figure 4.5 Processes and Material Selection in DFM

### DFM for Mecanum Wheel

DFM is used to find out the optimum manufacturing processes to manufacture the wheel plate and rollers. The user has to select following processes for individual parts.

## **Mecanum Plate**

The process selected for Mecanum plate is stamping. As user can make dies for plate material and using stamping as process the user can manufacture these plates in the quickest way possible. The next step is to apply given material to plate. As expected target is to produce Mecanum wheel with less weight because of the total weight constraint, user needs a light weight material that is strong and stable at the same time. It can be selected from a wide variety of Aluminum alloys. After selecting machining process and material, analysis is carried on it. The same process is repeated with the roller for its polymer material.

### **7.2.DFA**

DFA stands for 'Design for Assembly'. DFA is used to calculate the assembly cost of a given part. The assembly cost can include the labor cost, material cost, special machining cost, scrap cost and time for processing given operation on relative machine. Advantage of using DFA is that it can import DFM files directly into its system.

DFA consists of the following steps:

1. Assembly part insertion
2. Selection of part number and its repeat count
3. Item specification (weight limit)
4. Dimensioning of part
5. Item function (the way it is connected with other parts in the assembly)
6. Symmetry of that part (either no axis, one axis, two axis)
7. Handling requirements
8. Handling difficulties

9. Securing process (the process with which it is attached or fastened)
10. Operation characteristics
11. Manufacturing data (with piece part cost, item cost and tooling investment)

The following guidelines are applied to the DFA analysis on the given part.

The schematic representation about the steps is given in Figure 4.6.

The screenshot displays the DFA Software Analysis Chart for a motor assembly. The interface is divided into several sections:

- Motor assembly tree:** Lists components such as motor base, bushing, Press fitting, motor, motor screw, standoff, sensor, set screw, end plate, end plate screw, grommet, Feed wire/cable (push and pull), Reorientation of assembly, cover, and cover screws.
- Item analysis:**
  - Part number: 9584
  - Repeat count: 2
  - Cost of special assembly tools, \$: 0.00
  - Item weight:  Less than 5 lb (2.27kg)
  - Envelope dimensions, in: 0.200 x 0.500
  - Item function:  Fasten or secure other items
- Symmetry:** 180 degrees or less about:  No axes,  One axis,  Two axes
- Handling requirements:**
  - One hand without grasping tool
  - One hand using grasping tool
  - Two hands due to flexibility
  - Two hands - severe nest or tangle
- Handling difficulties:**
  - Nest or tangle
  - Stick together
  - Slips from fingers
  - Requires careful handling
- Securing process:**
  - Added not secured
  - Added and held down
  - Snap/push fitting
  - Threaded fastening
  - Pop Rivetting
  - Self-stick securing
- Operation characteristics:**
  - Power tool:
  - Nut/screw driver:
  - Ratchet wrench:
  - Open end wrench:
  - Box end wrench:
  - Number of revolutions: 5
- Insertion difficulties:**
  - Not self-locating
  - Holes require alignment with tool
  - Access to mating location obstructed
  - Sight of mating location restricted
- Manufacturing data:**
  - Piece part cost, \$: 0.03
  - Item cost, \$: 0.03
  - Tooling investment, \$: 0.00
- Notes:** These are separate fasteners and do not meet the criteria for minimum parts.
- Thumbnail picture:** Load file

**Results per entry for: end plate screw** | Process time = 18.12s | Process cost = \$0.15 | Assembly tool or fixture cost = \$0.00 | Item cost = \$0.06 | Total cost = \$0.21 | DFMA

Figure 4.6 DFA Software Analysis Chart

## Comparison of Different Materials Using DFM Analysis

The following chart shows the different material which can be used as a roller material and gives the total investment for each selected material. The comparison is done with factors such as material value, setup cost, rejected parts cost, tooling cost, total manufacturing cost and the complete investment cost.

Table 2. DFM Analysis of Roller Material

	<b>High impact Polystyrene (\$)</b>	<b>High Density Polyethylene (\$)</b>	<b>ABS (\$)</b>	<b>Ethylene Propylene (\$)</b>	<b>Silicone Shore 70 (\$)</b>	<b>Ethylene Propylene Diene Monomer (\$)</b>
<b>Material</b>	0.02	0.01	0.03	0.06	0.06	0.05
<b>Setup</b>	0.05	0.05	0.05	0.05	0.05	0.05
<b>Process</b>	1.24	0.61	1.17	1.15	1.05	1.68
<b>Rejection</b>	0.01	0.00	0.01	0.01	0.01	0.01
<b>Piece Part</b>	1.31	0.68	1.26	1.27	1.17	1.79
<b>Tooling</b>	1.23	1.23	1.23	1.23	1.23	1.90
<b>Total</b>	2.55	1.91	2.49	2.50	2.41	3.68
<b>Total Investment</b>	<b>14,471</b>	<b>12,333</b>	<b>14,471</b>	<b>12,333</b>	<b>12,333</b>	<b>18,984</b>

## 8. Conclusion

The following are conclusions based on this research:

1. Aluminum is selected as the material for manufacturing of Mecanum plate. ABS and Polyurethane are selected for Mecanum rollers. Polyurethane 75A polymer has high tensile strength of 4,600 psi and split tear resistance of 70 pli. ABS polymer has high density value of  $0.0376 \text{ kg/m}^3$  and it works at maximum temperature of  $89^{\circ}\text{C}$ .
2. The current work is done for the maximum limit of 68.03 kg on rollers. This is the maximum load application to estimate the values of coefficient of friction.
3. Experiments are done to find the coefficient of friction of the rollers with different surfaces. The high values of coefficient of friction are produced by concrete surface and the sand paper surface as 0.65 and 0.67 respectively. The rollers are tested on ice and grease. It gave the least values of coefficient of friction as 0.08 and 0.06 respectively.
4. The DFMA software is used to find the Design for Manufacturing and Design for Assembly costs. Design for Manufacturing estimated the total product cost for Mecanum plate came as \$49.38. The total tooling investment for Mecanum plate manufacturing came as \$9,453.
5. Design for manufacturing cost for Mecanum wheel rollers gave total product cost per part as \$0.57 and initial tooling investment with \$28,443.
6. Design for assembly for Mecanum rollers estimated total assembly labor time as 12.91 seconds and total processing cost per part as \$0.46.

## 9. Future Suggestions

- I. To carry out an assembly of polyurethane, ABS and brass sleeve. At present, these materials are mounted on each other's surface. There is a possibility that these materials will slip on each other. This will affect the working of robot and its motion.
- II. The application of strong adhesive between the given surfaces to strengthen the rollers.
- III. The design shows many open areas near the attachment of roller to the plate. This gives opportunity to work on the design aspect. The current design is not applicable for the motion of robot through sand or muddy area.
- IV. To increase the load carrying capacity of robot, it is required to change the design or material of the Mecanum wheel. The given load is applied through roller to the screw assembled to it. In case, the screw breaks or bends, that the particular roller will not work and will stop the robot.
- V. The current Mecanum wheel attachment to its roller base does not have suspension. Adding a suspension on Mecanum plate, it can absorb the sudden impacts on robot. It will improve the performance and life of the robot.
- VI. The current designed robot moves with limited speed. Future work can be related to increase the robot's flexibility and speed.

## REFERENCES

- [1] Fiegel, O., A. Badve and G. Bright, et al. “Improved Mecanum Wheel Design for Omni-Directional Robots”. Proc Australasian Conf. Robotics & Automation, 27-29 Nov. 2002.
- [2] Shigley, J. E., and Mischke, C. R., Mechanical Engineering Design, McGraw-Hill Inc., New York, 1989.
- [3] Badve AA. All Terrain Omni-Directional Autonomous Mobile Robot, Master’s Thesis, Massey University, Auckland, New Zealand 2003.
- [4] Dubowsky, S., Genot, F., Godding, S., Kozono. H, Skwersky, A., Yu, H., and Yu, L., “PAMM – A Robotic Aid to the Elderly for Mobility Assistance and Monitoring: A Helping-Hand for the Elderly”. IEEE International Conference on Robotics and Automation. pp. 47-52. 2001.
- [5] M. de Villiers, G. Bright., Council for Scientific & Industrial Research, Pretoria “Development of a Control Model for a Four Wheel Mecanum Vehicle”, pp. 1-7. 2008.
- [6] AndyMark.com, Mecanum Wheels – AndyMark. N.P., 2015.
- [7] Hamid Tahedi, Bing Quio., “Kinematic Model of a four Wheeled Mobile Robot”, pp 1-2. 2007.
- [8] Keith Schlee, Mecanum Wheel Summary, Helical Robotics. 2009.
- [9] Dewan Muhammad Nuruzzaman, Mohammad Asaduzzaman, “Friction & Wear of Polymer and Composite”, <http://dx.doi.org/10.5772/48246>, pp.1-19. 2003.
- [10] Laumond, J.P., 1998, “Robot Motion Planning and Automation”, 2006. Vol. 10, No.4, pp. 480-489. 2008.
- [11] West, M., and Asada, H., “Design of Ball Wheel Mechanism for Omnidirectional Vehicles with Full Mobility and Invariant Kinematics”, Journal of Mechanical Design, Vol. 119, pp. 153-161. 2002.
- [12] Kim, K. U., and Shin, B. S. “Modeling Motion Resistance of Rigid Wheels.” Journal of Terramechanics, 22(4), pp. 225-236. 1986.
- [13] M. de Villiers, N. S. Tlale, “Development of a Control Model for a Four Wheel Mecanum Vehicle”, J. of Dynamic Systems, Measurement, and Control, 134 011007, 2012.

- [14] P. F. Muir and C. P. Neuman, "Kinematic Modeling of Wheeled Mobile Robots", Technical Report CMU-RI-TR-86-12, Robotics Institute, Carnegie Mellon University, June 1986.
- [15] Online: [http://www.cord.edu/dept/physics/p128/lecture99\\_12.html](http://www.cord.edu/dept/physics/p128/lecture99_12.html), web site of the Physics, Department at Concordia University containing physics lectures, 2011.



## APPENDIX A

This section contains the results from DFM analysis on Mecanum Plate.



Tuesday, October 27, 2015

### Analysis Totals for Design for Manufacture and Assembly (DFMA)

Per product costs, \$		Original
Assembly process		0.42
Manufacturing piece part		48.01
<b>Total cost without tooling</b>		48.44
Total tooling cost		0.95
<b>Total cost</b>		49.38

Total tooling investment, \$	
Assembly tools and fixtures	0
Manufacturing tooling	9,453
<b>Total investment</b>	9,453

Production life data and weight	
Life volume	10,000
Total production life cost, \$	493,820
Total weight, lb	8.05

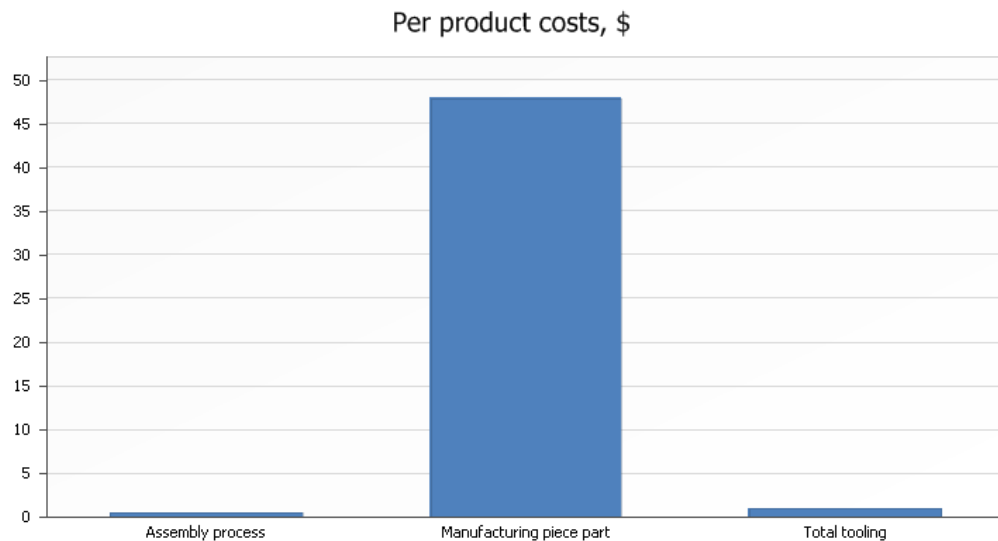

Figure 4.7 Manufacturing Cost per Product

## DFM Concurrent Costing Executive Summary

*Boothroyd Dewhurst, Inc.*



Tuesday, October 27, 2015 3:59 PM  
 Part name: Plate  
 Material: PH stainless steel  
 Process: Compound die stamping

Untitled1.dfm  
 Original  
 Part number: 1

Product life volume	100,000
Batch size	12,500
Total cost, \$	48.17
Piece part cost, \$	47.60
Initial tooling investment, \$	57,468

**The chart shows a breakdown of the costs, \$**

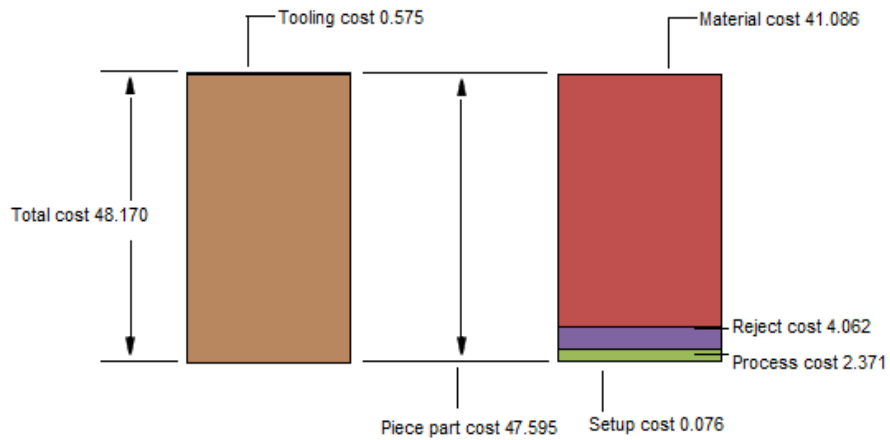

Figure 4.8 DFM Cost Breakdown

**DFM Concurrent Costing Results**  
Boothroyd Dewhurst, Inc.



Tuesday, October 27, 2015 4:01 PM  
Original

Untitled1.dfm  
Part weight: 7.996 lb

Process Chart	Batch Size	Cost per part, \$							Operation time per part, s	Initial tooling investment
		Material	Setup	Process	Rejects	Piece part	Tooling	Total		
<b>PH stainless steel sheet metal part</b>		41.09	0.08	2.37	4.06	47.60	0.57	48.17	164.87	57,468
<b>Compound die stamping process</b>	12,500	41.09	0.08	2.37	4.06	47.60	0.57	48.17	164.87	57,468
<b>Komatsu SHS6X620 Power Shear</b>			0.00	0.04	0.20	0.24		0.24	2.60	
Load sheet and remove scrap			0.00	0.02		0.02		0.02	1.35	
Power shear operation				0.02		0.02		0.02	1.25	
<b>Minster E2-600 Hevistamper (600 ton)</b>			0.02	0.25	0.20	0.46	0.11	0.57	11.95	10,730
Load and advance strip			0.02	0.12		0.14	0.11	0.25	5.95	10,730
Compound die operation				0.12		0.12		0.12	6.00	
<b>Minster OBI #6F (60 ton)</b>			0.00	0.12	0.20	0.33	0.03	0.35	8.84	2,544
Load and unload part			0.00	0.09		0.09	0.03	0.12	6.44	2,544
Punch holes				0.03		0.03		0.03	2.40	
<b>Minster OBI #6F (60 ton)</b>			0.00	0.12	0.20	0.33	0.03	0.36	8.84	2,544
Load and unload part			0.00	0.09		0.09	0.03	0.12	6.44	2,544
Punch holes				0.03		0.03		0.03	2.40	

www.dfma.com

Page 1 of 5

**DFM Concurrent Costing Results**  
Boothroyd Dewhurst, Inc.



Tuesday, October 27, 2015 4:01 PM  
Original

Untitled1.dfm  
Part weight: 7.996 lb

Process Chart	Batch Size	Cost per part, \$							Operation time per part, s	Initial tooling investment
		Material	Setup	Process	Rejects	Piece part	Tooling	Total		
Load and unload part			0.00	0.09		0.09	0.03	0.12	6.44	2,544
Punch holes				0.03		0.03		0.03	2.40	
<b>Minster OBI #6F (60 ton)</b>			0.00	0.12	0.21	0.34	0.03	0.37	8.84	2,544
Load and unload part			0.00	0.09		0.09	0.03	0.12	6.44	2,544
Punch holes				0.03		0.03		0.03	2.40	
<b>Minster OBI #6F (60 ton)</b>			0.00	0.12	0.22	0.34	0.03	0.37	8.84	2,544
Load and unload part			0.00	0.09		0.09	0.03	0.12	6.44	2,544
Punch holes				0.03		0.03		0.03	2.40	
<b>Minster OBI #6F (60 ton)</b>			0.00	0.12	0.22	0.34	0.03	0.37	8.84	2,544
Load and unload part			0.00	0.09		0.09	0.03	0.12	6.44	2,544
Punch holes				0.03		0.03		0.03	2.40	
<b>Minster OBI #6F (60 ton)</b>			0.00	0.12	0.22	0.34	0.03	0.37	8.84	2,544
Load and unload part			0.00	0.09		0.09	0.03	0.12	6.44	2,544

www.dfma.com

Page 3 of 5

Figure 4.9 Process Chart for Mecanum Plate Manufacturing

## APPENDIX B

This section contains the results from DFM analysis on Mecanum rollers.



### DFM Concurrent Costing Executive Summary *Boothroyd Dewhurst, Inc.*

Sunday, November 01, 2015 10:07 PM  
Part name: Roller  
Material: ABS  
Process: Injection molding

Untitled0.dfm  
Original  
Part number: 1

Product life volume	100,000
Batch size	10,000
Total cost, \$	0.57
Piece part cost, \$	0.29
Initial tooling investment, \$	28,443

The chart shows a breakdown of the costs, \$

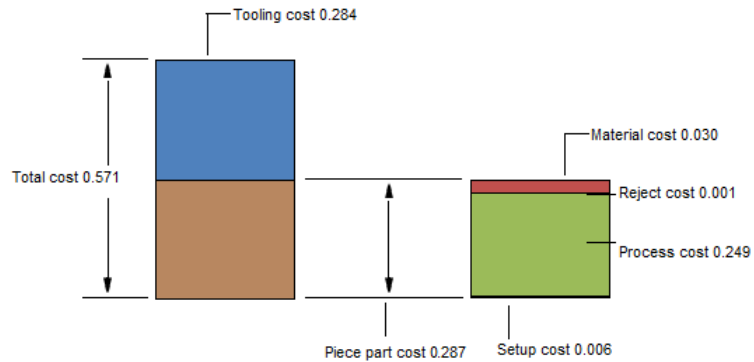

Figure 5.0 DFM Analysis for Injection Molding

## DFM Concurrent Costing Responses

*Boothroyd Dewhurst, Inc.*



Sunday, November 01, 2015 10:08 PM

Untitled0.dfm

### ABS injection molded part

Part name	Roller
Part number	1
Life volume	100,000
Envelope shape	Hollow cylinder
Forming direction	Z
Z Dimension, in.	1.511
Y Dimension, in.	0.742
X Dimension, in.	0.742
Average thickness, in.	0.370

### Injection molding process

#### *Part basic data*

Batch size	10000
Overall plant efficiency, %	95.0
Material cost, \$/lb	1.200
Colored resin?	no
Maximum regrind, %	30.0
Maximum thickness, in.	0.370
Material scrap value, \$/lb	0.170

#### *Part geometry*

Part volume, in <sup>3</sup>	0.653
Part weight, lb	0.025
Part projected area, in <sup>2</sup>	0.411

#### *Part complexity*

Surface patches	127
-----------------	-----

#### *Part non-geometric features*

Tolerance	most 0.005 to 0.01 in/in
Appearance	Minimum finish
Textured surface, %	0

#### *Mold data*

Parting line	simple curved surface
Runner system	Hot runner
Mold material	Aluminum
Inserts per cavity	0
Automatically select cavities?	yes
Number of cavities	4
<b><i>Injection Mold devices</i></b>	
Core pulls on left	0
Core pulls on right	0
Core pulls on top	0
Core pulls at bottom	0
Unscrewing cores on left	0
Unscrewing cores on right	0
Unscrewing cores on top	0
Unscrewing cores at bottom	0
Unscrewing cores at rear	0
Number of lifters	0

### Battenfeld BA 400/125 CDC

#### *Machine selection*

Automatic selection?	yes
----------------------	-----

#### *Machine data*

Clamping force, tons	45.0
Shot capacity, in <sup>3</sup>	3.860
Dry cycle time, s	1.36
Max. mold opening, in.	12.800
Driving power, hp	10.06
Number of machines per operator	
with hot runner system	4.00
Machine rate, \$/hr	13.00
Operator rate, \$/hr	25.00
Process rate, \$/hr	19.25

www.dfma.com

Page 1 of 2

Figure 5.1 DFM Report for Manufacturing Factors of Roller

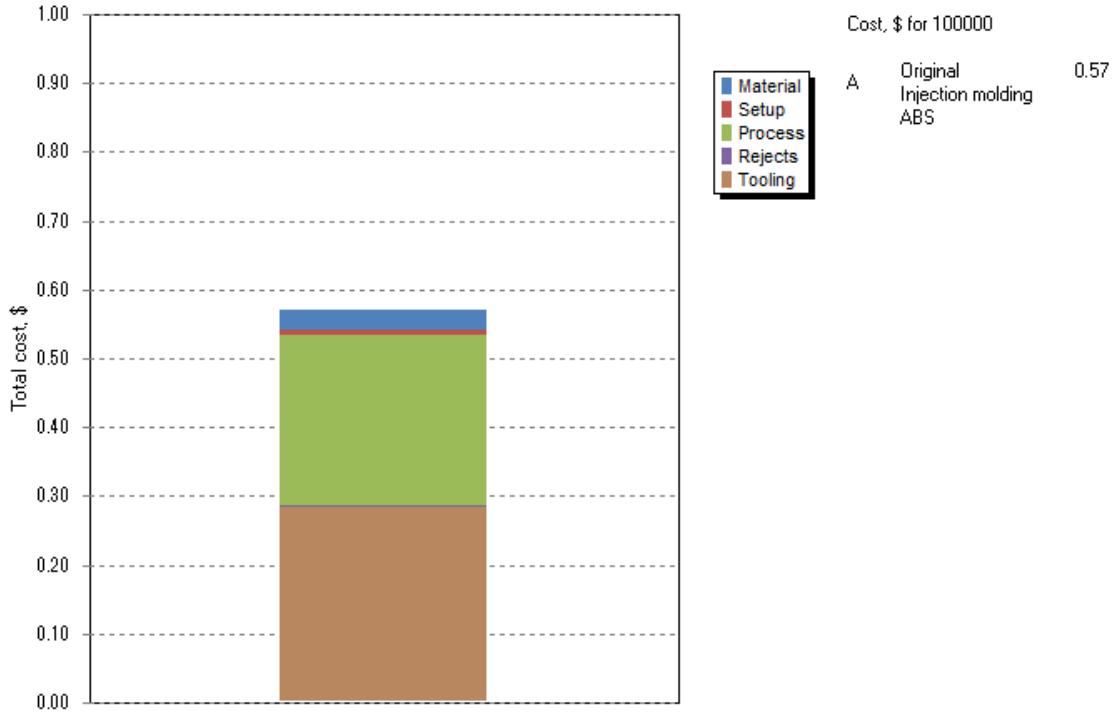

**DFM Concurrent Costing Responses**  
Boothroyd Dewhurst, Inc.



Sunday, November 01, 2015 10:08 PM

Untitled0.dfm

Rejects, %	0.5
<b>Injection mold</b>	
<b>Machine setup</b>	
Machine rate during setup, \$/hr	13.00
Setup operator rate, \$/hr	30.00
Setup rate, \$/hr	43.00
Setup time, hr	1.50
<b>Molding process data</b>	
Cavity life	25000
Fill time, s	1.46
Cooling time, s	173.05
Mold reset time, s	2.49
Cycle time, s	177.00
<b>Mold cost data</b>	
Mold base purchase cost, \$	1,700
Mold base custom work, \$	1,650
Cavity/core manufacture, hrs	365.46
Hot runner time, hrs	232.00
Total mold hours	597.46
Mold manufacturing rate, \$/hr	42.00

Figure 5.2 DFM Analysis of Cost Distribution

## APPENDIX C

This section contains the results from DFA analysis on Mecanum rollers.

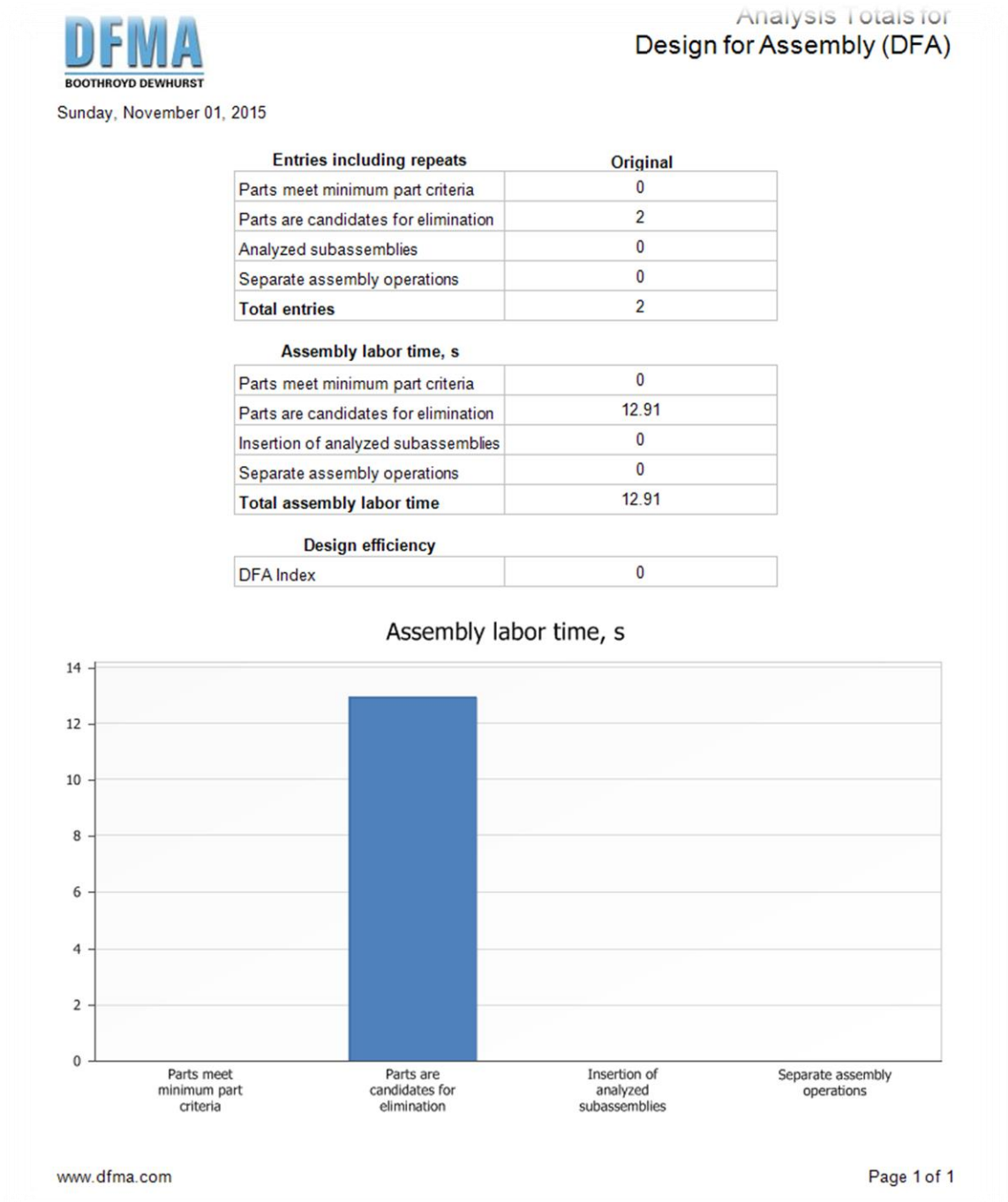

Figure 5.3 DFA Assembly Labor Time

Sunday, November 01, 2015

Per product costs, \$	Original
Assembly process	0.17
Part cost without tooling	0.29
<b>Total cost without tooling</b>	<b>0.46</b>

Production life data and weight	
Life volume	10,000
Total weight, lb	0.02

Per product costs, \$

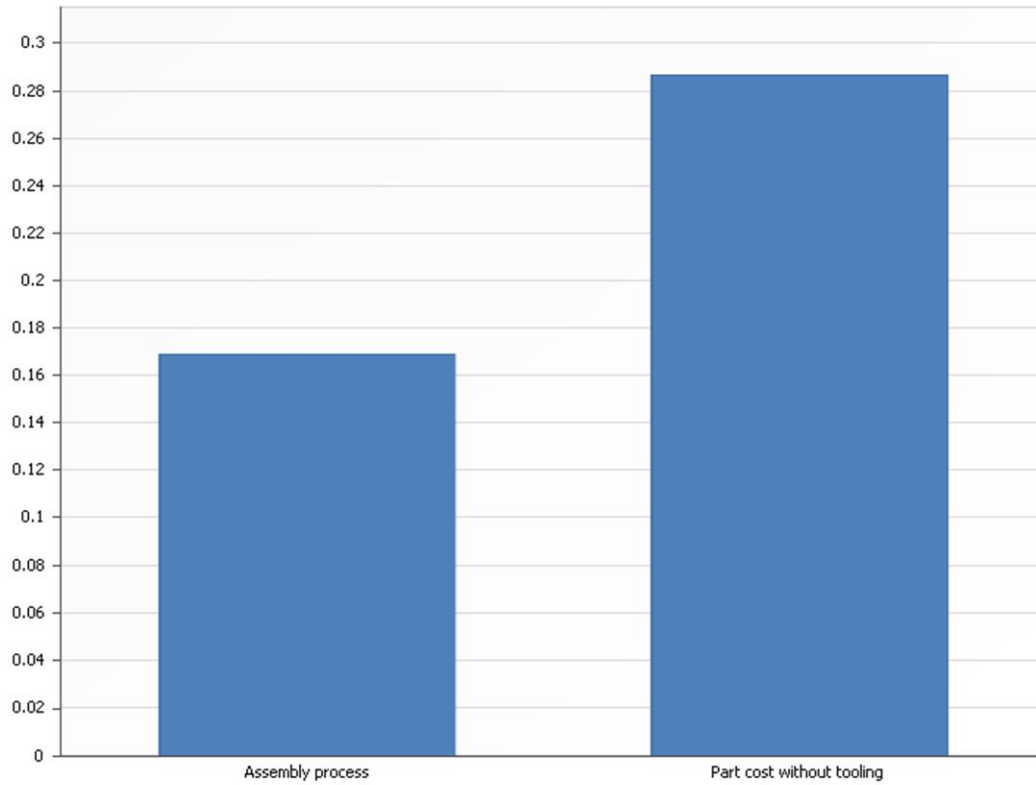

Figure 5.4 DFA for Part per Production Assembly



Sunday, November 01, 2015

Per product costs, \$	Original
Assembly process	0.17
Manufacturing piece part	0.29
<b>Total cost without tooling</b>	<b>0.46</b>
Total tooling cost	0.28
<b>Total cost</b>	<b>0.74</b>

Total tooling investment, \$	
Assembly tools and fixtures	0
Manufacturing tooling	2,844
<b>Total investment</b>	<b>2,844</b>

Production life data and weight	
Life volume	10,000
Total production life cost, \$	7,397
Total weight, lb	0.02

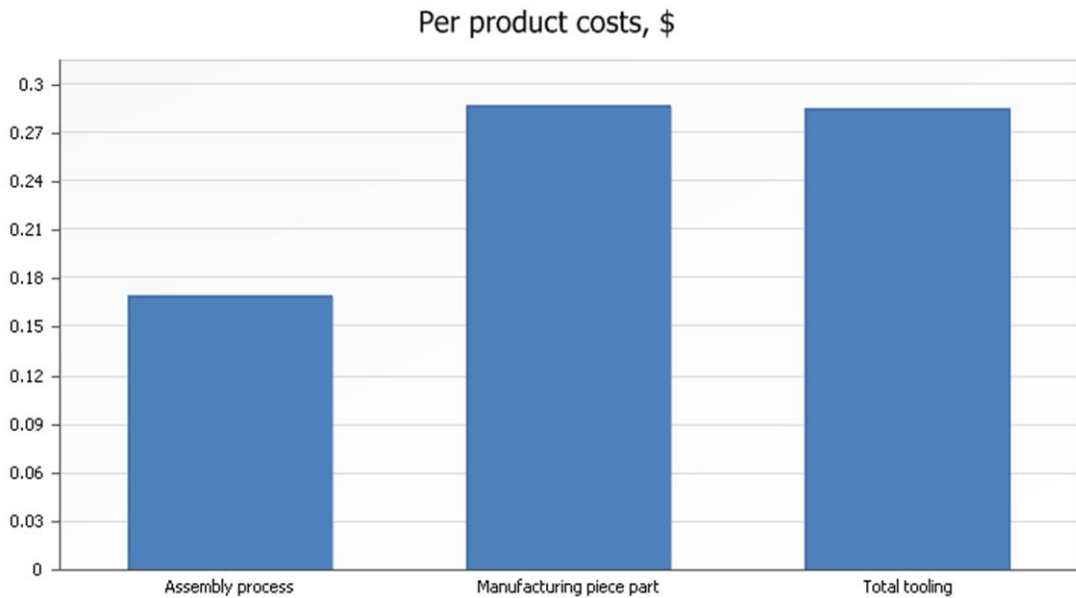

Figure 5.5 DFA result for Production Cost with Tooling Investment

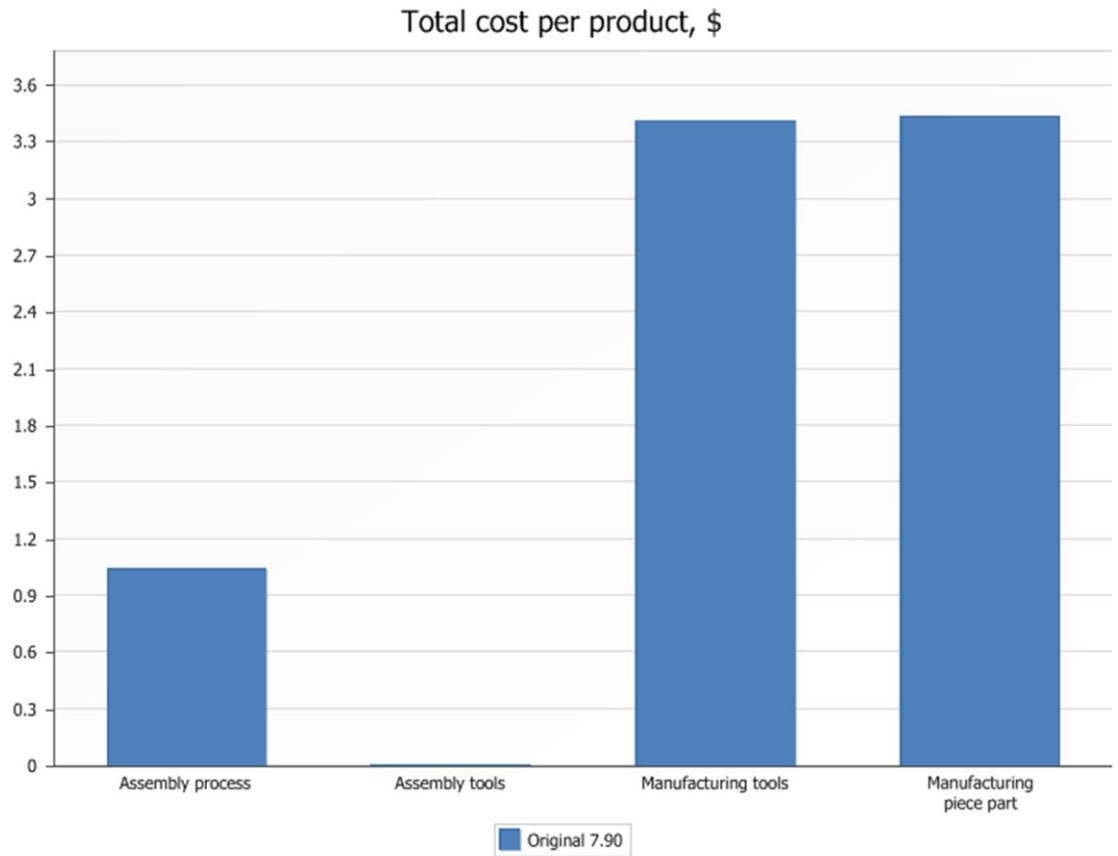

Figure 5.6 DFA Comparison of Different Product Assembly Processes