



Investigating the Magnetic Actuation of Dynamic Cell Culture



Ashlyn Thorpe, Aeson Coen, Miguel Delgado, Dr. Foram Madiyar

Embry Riddle Aeronautical University, College of Arts and Sciences, Department of Physical Sciences

Abstract:

- There are various methods to observe how dynamic cell culture reacts to various stimuli and environment changes.
- Our goal, to develop a magnetic actuation system, (M.A.S.), that can accurately and precisely interact with the culture.
- A biocompatible, tunable magnetic-poly lactic-co-glycolic acid (magnetic PLGA) porous composite can be used to develop a scaffold to house dynamic cell culture.
- The scaffold will then interact with the magnetic actuation system and in turn actuate the cell culture.
- Magnetic actuation serves as a more accurate, easy, and seamless method of interaction with dynamic cell culture that can be programmed to simulate specific environments.

Purpose:

Provide an easily programmable system that can be altered for use in various sectors of medicine and astrobiology that uses magnetism and magnetic PLGA composite scaffolds to observe dynamic cell culture behavior.

Methodology – System Development:

- The M.A.S. is designed to be easily operable and maintained. Printed with a nylon composite material to provide high durability and low weight.
- Layers 1(a) and 1(b) are electronics bays.
- Layer 1(c) provides room for linear actuation of magnets.
- Each section [Items 1(a) through 1(d)] are separable, giving ease of access to the user.
- Images 2 and 3 denote fixtures to attach each section and were printed separately during manufacturing to save on print time and material costs. Standardized nuts and bolts are used to affix layers together.
- Note 1(e) denotes slats printed in the base of section 1(b) to provide air circulation through the electronics bays. Additionally, slats reduce production cost and manufacturing time.
- Note 1(f) is the location of the scaffolds.
- Note 1(g) denotes ultra-sonic distance sensor port. This sensor is used to measure distance from magnets to scaffolding.

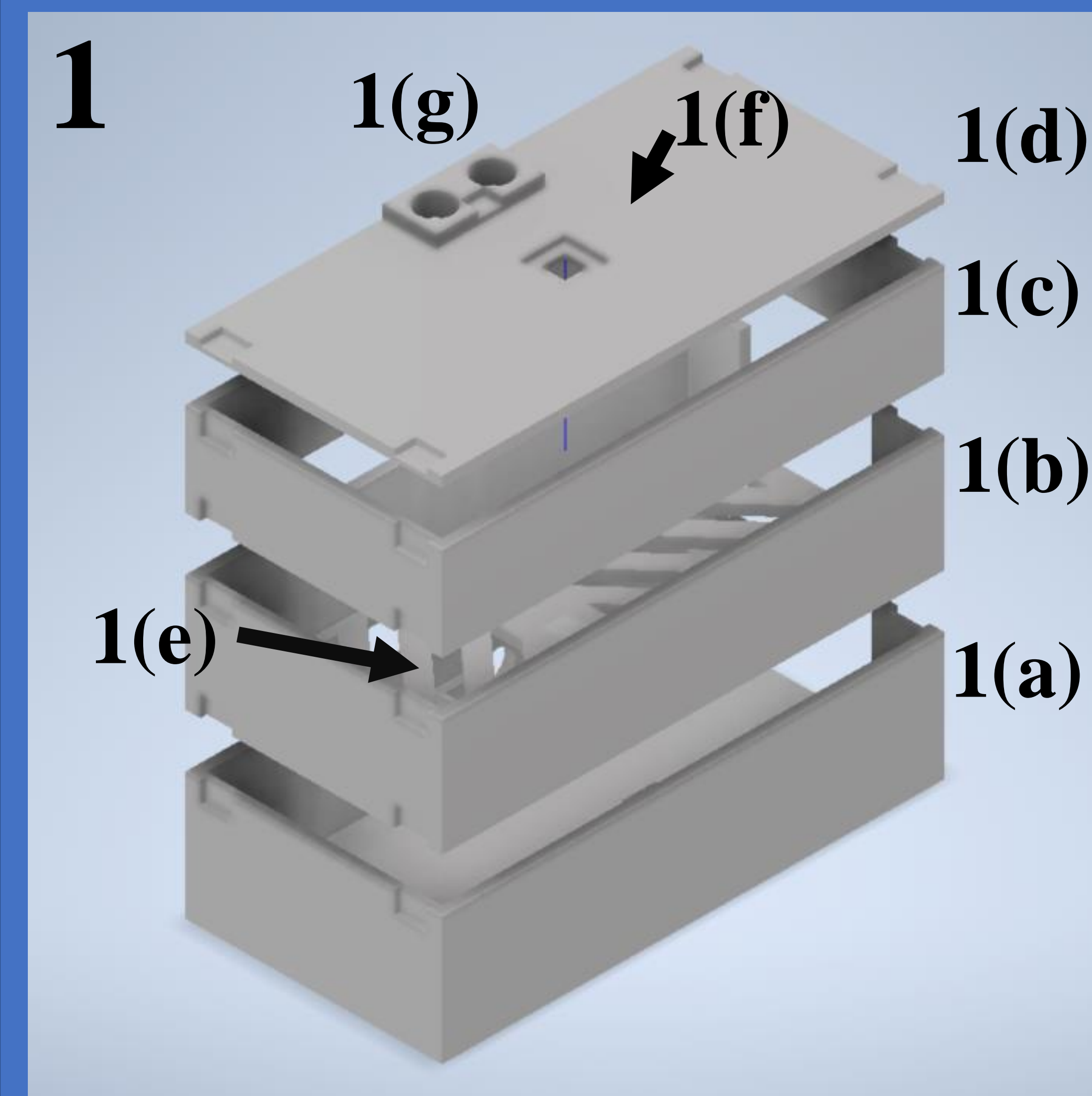

Image 1: Full assembly of 3D modeled M.A.S. with labeled components

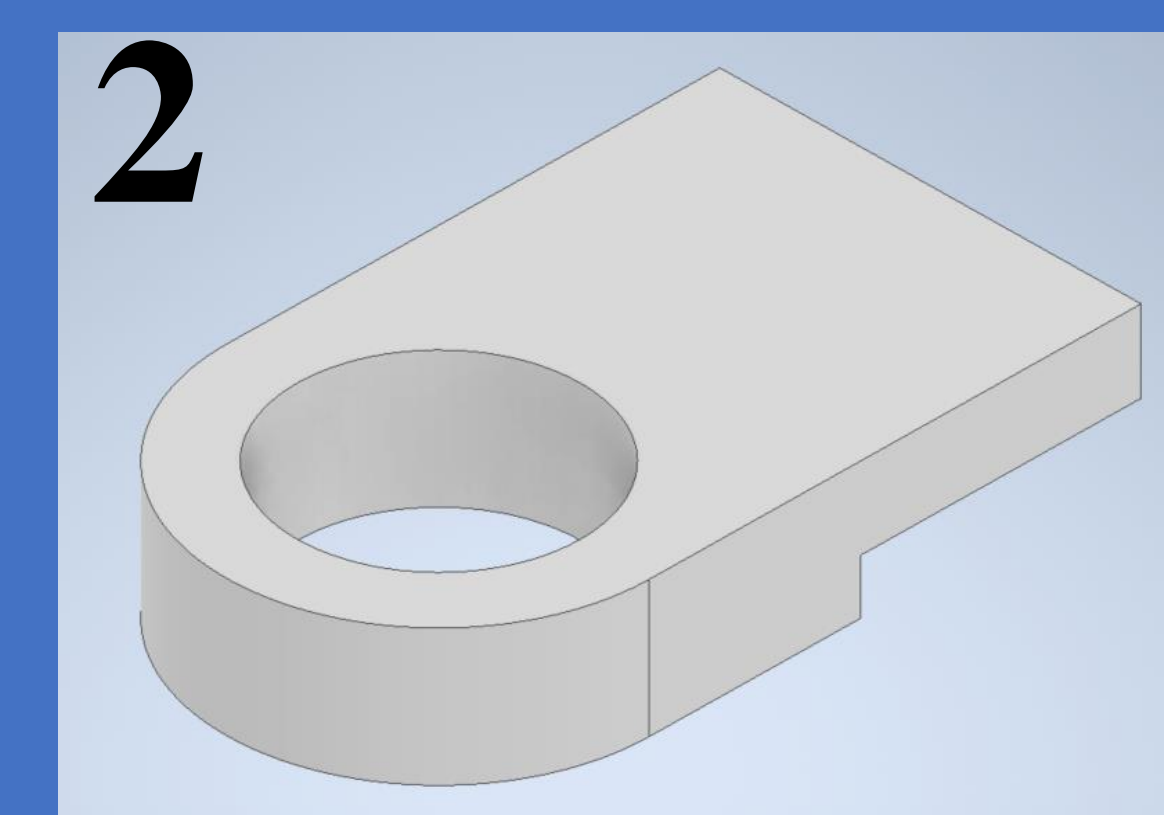

Image 2: Layer 1(d) fixtures

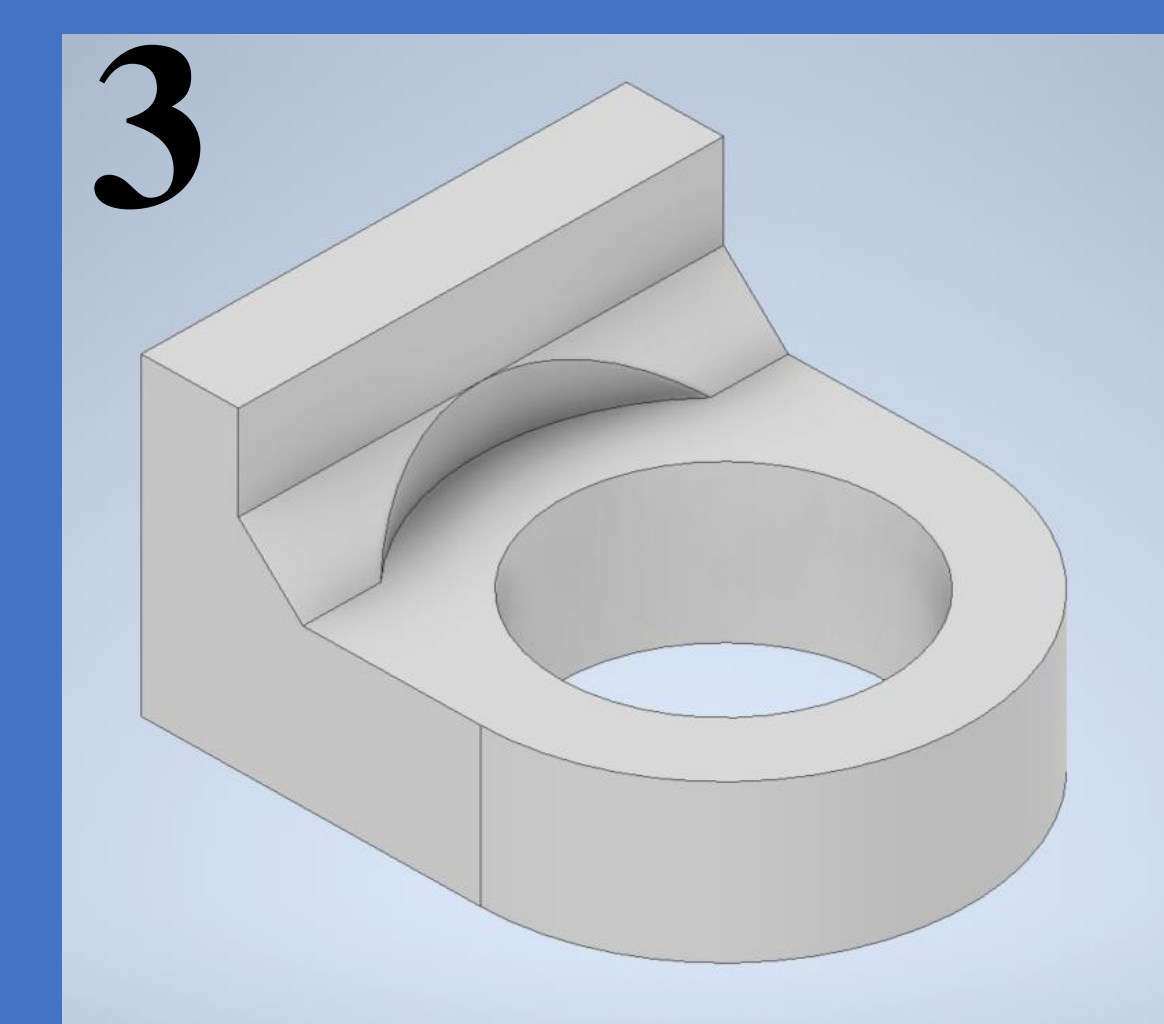
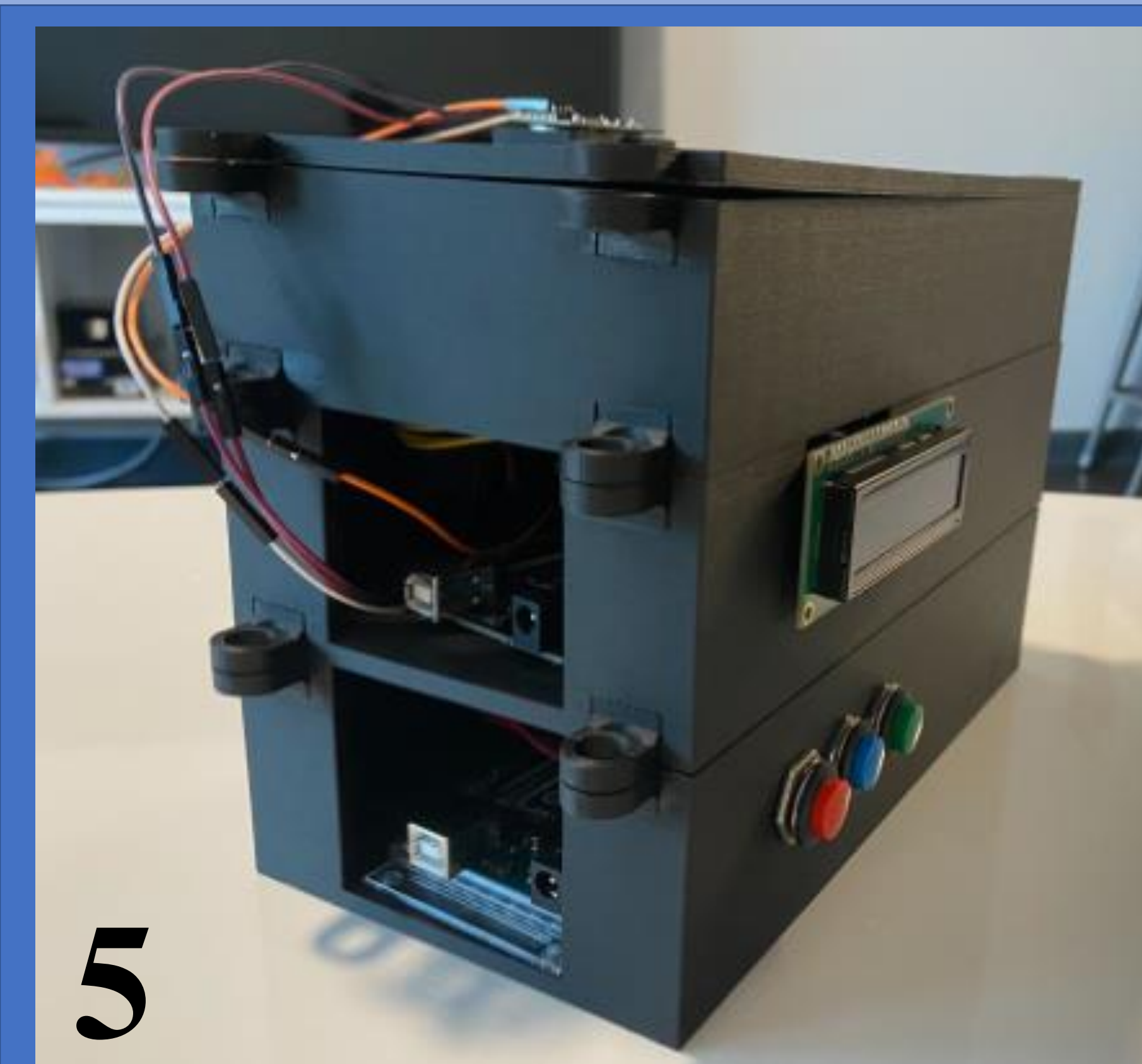

Image 3 Layers 1(a)-1(c) fixtures



Image 4: Mini Linear Actuator used to move the plate that holds the magnet in the M.A.S. These actuators can be programmed to actuate at specific frequencies.



5



6

Image 5: Printed and assembled M.A.S. side view
Image 6: Printed and assembled M.A.S. front view

Acknowledgements:

- This research is possible through the support and funding provided through the Office of Undergraduate Research (OUR) at Embry Riddle Aeronautical University

Methodology – Electronics Development

- Arduino hardware and IDE were utilized.
- 2 mini linear actuators, Image 4, were interfaced with two Arduino motor drivers and an Arduino Uno with button controls.
- Additionally, an LCD screen and ultrasonic distance sensor were included for real-time distance measurements between culture and magnet.