

The Space Congress® Proceedings

2004 (41st) Space Congress Proceedings

Apr 28th, 8:00 AM

Paper Session I-B - An Operational System for Launch Area Hazard Prediction and Mitigation

Allan Dianic

ENSCO, Inc., 1980 N. Atlantic Ave. Suite 230, Cocoa Beach, Florida 32931

Erik Magnuson

ENSCO, Inc., 1980 N. Atlantic Ave. Suite 230, Cocoa Beach, Florida 32931

Follow this and additional works at: <https://commons.erau.edu/space-congress-proceedings>

Scholarly Commons Citation

Dianic, Allan and Magnuson, Erik, "Paper Session I-B - An Operational System for Launch Area Hazard Prediction and Mitigation" (2004). *The Space Congress® Proceedings*. 28.

<https://commons.erau.edu/space-congress-proceedings/proceedings-2004-41st/april-28/28>

This Event is brought to you for free and open access by the Conferences at Scholarly Commons. It has been accepted for inclusion in The Space Congress® Proceedings by an authorized administrator of Scholarly Commons. For more information, please contact commons@erau.edu, wolfe309@erau.edu.

EMBRY-RIDDLE
Aeronautical University,[™]
SCHOLARLY COMMONS

For consideration for paper session 1B (Technology Solutions Delivered to Operational Space Programs) of the 41st Space Congress

An Operational System for Launch Area Hazard Prediction and Mitigation

Mr. Allan Dianic*, Mr. Erik Magnuson
ENSCO, Inc.
1980 N. Atlantic Ave. Suite 230
Cocoa Beach, Florida 32931

ABSTRACT

The Meteorological And Range Safety Support (MARSS) system provides the Air Force and NASA with a combined meteorological/toxic hazard support capability to protect personnel and property engaged in vehicle processing, material handling, launch preparation and launch support activities. The primary users for MARSS are the Air Force's 45th and 30th Space Wings and NASA's Kennedy Space Center. These organizations provide joint base toxic and hazard support activities for their facilities, personnel and surrounding communities.

The MARSS system is the result of a highly successful technology transfer from innovative research to operational product and provides:

- Quality analysis of weather measurements from over 70 different instruments
- Extensive set of meteorological and hazard prediction tools for 2 and 3-dimensional toxic material release, blast hazards and risk to human life
- Use of expert systems technology to monitor real-time weather measurements in order to detect user specified hazardous conditions and alert when they are detected
- Continuous (24 hour/7 day) availability

The use of the MARSS system saves money through the improved efficiency of functional consolidation and integrated communication tools. A single user can now perform a series of support tasks that had previously taken 2-3 personnel. It further enhances communications between Government safety personnel and local town, county and state emergency response planners and personnel.

* Corresponding Author: Tel.: (321) 783-9735, ext. 207; email: dianic.allan@ensco.com

An Operational System for Launch Area Hazard Prediction and Mitigation

Mr. Allan Dianic, Mr. Erik Magnuson
ENSCO, Inc.
1980 N. Atlantic Ave. Suite 230
Cocoa Beach, Florida 32931

Abstract

The Meteorological And Range Safety Support (MARSS) system provides the Air Force and NASA with a combined meteorological/toxic hazard support capability to protect personnel and property engaged in vehicle processing, material handling, launch preparation and launch support activities. The primary users for MARSS are the Air Force's 45th and 30th Space Wings and NASA's Kennedy Space Center (KSC). These organizations provide joint base toxic and hazard support activities for their facilities, personnel and surrounding communities.

The MARSS system is the result of a highly successful technology transfer from innovative research to operational product and provides:

- Quality analysis of weather measurements from over 70 different instruments,
- Extensive set of meteorological and hazard prediction tools for 2- and 3-dimensional toxic material release, blast hazards and risk to human life,
- Use of expert systems technology to monitor real-time weather measurements in order to detect user specified hazardous conditions and alert when they are detected, and
- Continuous (24 hour/7 day) availability.

The use of the MARSS system saves money through the improved efficiency of functional consolidation and integrated communication tools. A single user can now perform a series of support tasks that had previously taken 2 - 3 personnel. It further enhances communications between Government safety personnel and local town, county and state emergency response planners and personnel.

Introduction

The MARSS system provides the Air Force and NASA with a combined meteorological/toxic hazard support capability to protect personnel and property engaged in vehicle processing, material handling, launch preparation and launch support activities. The primary user for MARSS is the 45th Space Wing Safety Office (45 SW/SE). The Safety Office provides joint base toxic and hazard support both for Air Force activities at the Cape Canaveral Air Force Station (CCAFS) as well as NASA operations at KSC. MARSS workstations have been installed in 45 SW/SE operational and administrative facilities. The 45 SW/SE also maintains a fully functional portable capability allowing remote access to MARSS through dial-up access. Additional units are deployed in the operations section of the 45th Weather Squadron as well as at the Kennedy Space Center in LC39 (Launch Control Centers 1 and 3), Radiation Control Center, Environmental Health Office and the Emergency Operations Center.

MARSS consists of a data acquisition component and a display component. The data acquisition component (known as the preprocessor or PPRO) retrieves measurements from the sensors, reformats them, performs a statistical quality control analysis and then disseminates all results to the display component (known as the Monitoring and Display Station or MDS). The two components may be operated on the same physical computer or on separate computers. There is no explicit limitation to the number display systems in the network and each is independent of all other systems. The acquisition

component monitors the communications status of all workstations in the network, retransmits data to those that were inoperative, and saves old data to archive media.

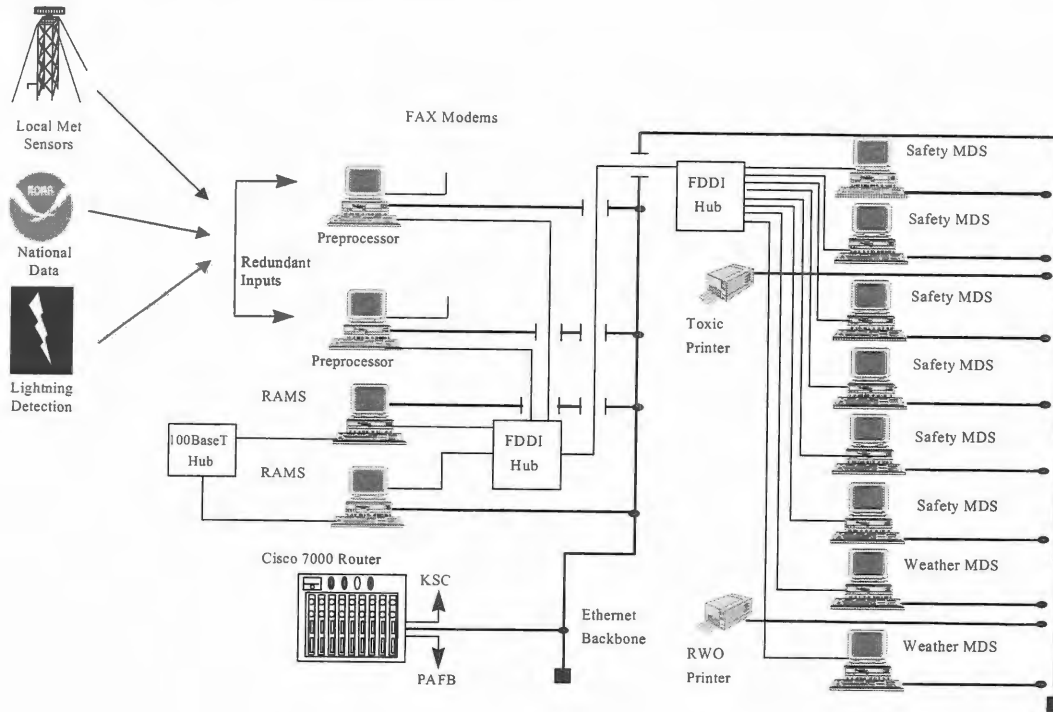

Figure 1. MARSS System

Mesoscale forecasting is currently performed by the Regional Atmospheric Modeling System (RAMS). The system is configured to produce a 24-hour forecast in a series of nested grids with the highest resolution set to 1.25 kilometers. Model output can be used for meteorological support and 3-dimensional toxic hazard predictions.

Data Acquisition

The MARSS/Eastern Range Dispersion Assessment System (MARSS/ERDAS) system is designed as a client-server distributed networked architecture of which the PPRO acts as a form of server to client MDS workstations. The PPRO stations are responsible for the collection, quality control, archive management, and dissemination of data. There are no data display functions on a PPRO but rather a set of control interfaces through which the administrator can monitor and control system functions. The currently deployed Eastern Range system acquires data from the following once received data are subjected to quality control analysis.

- Wind tower network,
- Upper-air soundings,
- Radar wind profilers (both 50-MHz and 915-MHz),
- Lightning detection systems, and
- Nationally distributed data products (Surface observations from stations in 25 states, numerical weather prediction products, upper-air, coastal data buoys, etc.).

The primary map display for MARSS (designated 'Windflow') depicts wind data in two forms. Data may be displayed as standard barbs for a sensor at a specified height and as an interpolated wind field. Windflow also provides calculation and display of toxic dispersion predictions produced by Ocean Breeze-Dry Gulch (OBDG) and Local Meteorology Puff (LOMPUFF), and the display of Rocket Exhaust Effluent Diffusion Model (REEDM) output distributed by safety analysts.



Figure 2. Windflow OBDG and LOMPUFF Displays

MARSS employs a framework approach to allow for easy integration of new models and displays into the suite of tools already available. MARSS provides execution control, input data, output dissemination and additional display capabilities for these tools, but their software is not structurally integrated into the system. This facilitates continuous improvements in model technology without having to re-test the entire system with every new model upgrade. The set of collaborative tools includes:

- Rocket Exhaust Effluent Diffusion Model (REEDM),
- Blast effects predictor (BLAST), and
- Hybrid Particle Concentration Transport (HYPACT).

The H.E. Cramer Company, Inc. developed REEDM originally in 1982 based on multilayer dispersion models from NASA's Marshall Space Flight Center and originally intended for the Space Shuttle. It has been used by the Air Force for applications involving Delta, Atlas and Titan launches in the intervening years. Range safety officers use REEDM as the basis of launch/no-launch determinations at CCAS and VAFB. This model is designed to take into account the fuel and oxidant load, as well as the local meteorology and terrain to predict pollutant concentrations as a function of time and distance after a launch event. The REEDM uses a chemical thermodynamic program (NASA Lewis Chemical Equilibrium CET 89) to estimate such quantities as peak temperature and cloud rise following an abort. Since its original development REEDM has undergone a continuous improvement through the Eastern and Western Ranges Safety offices. ACTA, Inc. is the principle contractor engaged by the U.S. Air Force to produce REEDM for operational use.

The blast effects predictor (BLAST) has been developed and modernized by ACTA, Inc. to quantify the consequences of explosions in the vicinity of launch sites. This model uses current meteorology as

successful program that ultimately delivered two subsequent versions over the next five years. Version 2 of MARSS was accepted by both the Eastern and Western Ranges after its release in 1989 and was followed by its final version one year later. A new project, the Meteorological Monitoring System (MMS), was started under NASA and was designed to provide a distributed real-time meteorological monitoring and display capability. With Air Force support the MMS was subsequently upgraded to include all of the functionality of the MARSS. MMS was redesignated as the MARSS Replacement system and was accepted by the Eastern Range in 1997. The MARSS Replacement (MARSS-REPL) system was itself upgraded by integrating it with the Eastern Range Dispersion Assessment System (ERDAS), a product of the Mission Research Corporation.

The original technological development of the current MARSS system originated as a NASA Phase II SBIR. NASA funded the Meteorological Monitoring System with technical participation and support coming from NASA Safety and the 45th Weather Squadron (USAF). The MMS acquired data for the primary purpose of detecting hazardous weather conditions and providing a sophisticated alerting mechanism to warn users when such conditions were detected. During operational evaluation by the 45th Weather Squadron, members of the 45th Safety Office became familiar with the system and its capabilities. Additional NASA funding extended the base Phase II SBIR to provide simple toxic hazard prediction capabilities. Shortly after the Phase II was completed the 45th Safety Office approached NASA to begin work on awarding a Phase III SBIR to ENSCO for the purpose of upgrading the currently operational MARSS system. The older MARSS had been in service since 1988 and was based on older hardware and software technology.

The base Meteorological And Range Safety Support (MARSS) Replacement (REPL) contract was awarded in February 1996 for the purpose of replacing the previous Eastern Range (ER) MARSS system with a newer, more robust and capable system. The major objectives of the MARSS-REPL system were:

- Greater reliability of user control and display functions,
- Expandable architecture,
- Improved data acquisition operations and reliability,
- Robust data communications, and
- Continuous (24 hour/7 day) availability.

The previous MARSS system was based upon a centralized architecture with remote graphical display terminals. The central processor was frequently over tasked and system response slowed significantly. System or communications failures occurred regularly and recovery required a minimum of 3-5 minutes to reinitialize the connection. Full system restarts took more than 10 minutes during which no user support was available.

The basic MARSS-REPL contract was amended in August 1997 to include a second delivery of a substantially upgraded system to include the Eastern Range Dispersion Assessment System (ERDAS) Replacement. The Government's objective for the ERDAS-REPL upgrade was the augmentation of the MARSS-REPL with the following new capabilities:

- Regional Atmospheric Modeling System (RAMS) mesoscale forecast model,
- Isentropic Analysis Package for data assimilation,
- Hybrid Particle and Concentration Transport for toxic/hazard prediction,
- Local execution of the Rocket Effluent Exhaust Diffusion Model,
- Local execution of the Blast effects predictor,
- Expansion of MDS workstations network, and the
- Addition of two portable MDS workstations with dial-in capability.

MARSS/ERDAS-REPL includes both the Preprocessor and MDS from MARSS-REPL and adds a third component: the RAMS Processor (RP). The Preprocessor's data acquisition was enhanced to include

data streams necessary for initialization of the RAMS mesoscale forecast model. These include inputs from the 50-MHz and 915-MHz radar wind profilers, global forecast model output produced by the National Center for Environmental Prediction (NCEP), coastal data buoys, regional surface observations and upper air soundings. This data is transferred to the RAMS processor that initializes every 12 hours and produces a 24-hour forecast. The Eastern Range RAMS uses a 4 level nested grid scheme with the finest horizontal resolution being 1.25 Km over a 90 x 74 inner grid. The inner grid has 36 vertical levels. Full moisture physics are active so that the model forecasts precipitation. In this configuration the full forecast cycle completes in approximately 10.5 to 11.5 hours. RAMS output is disseminated to the MDS network as each forecast hour is produced.

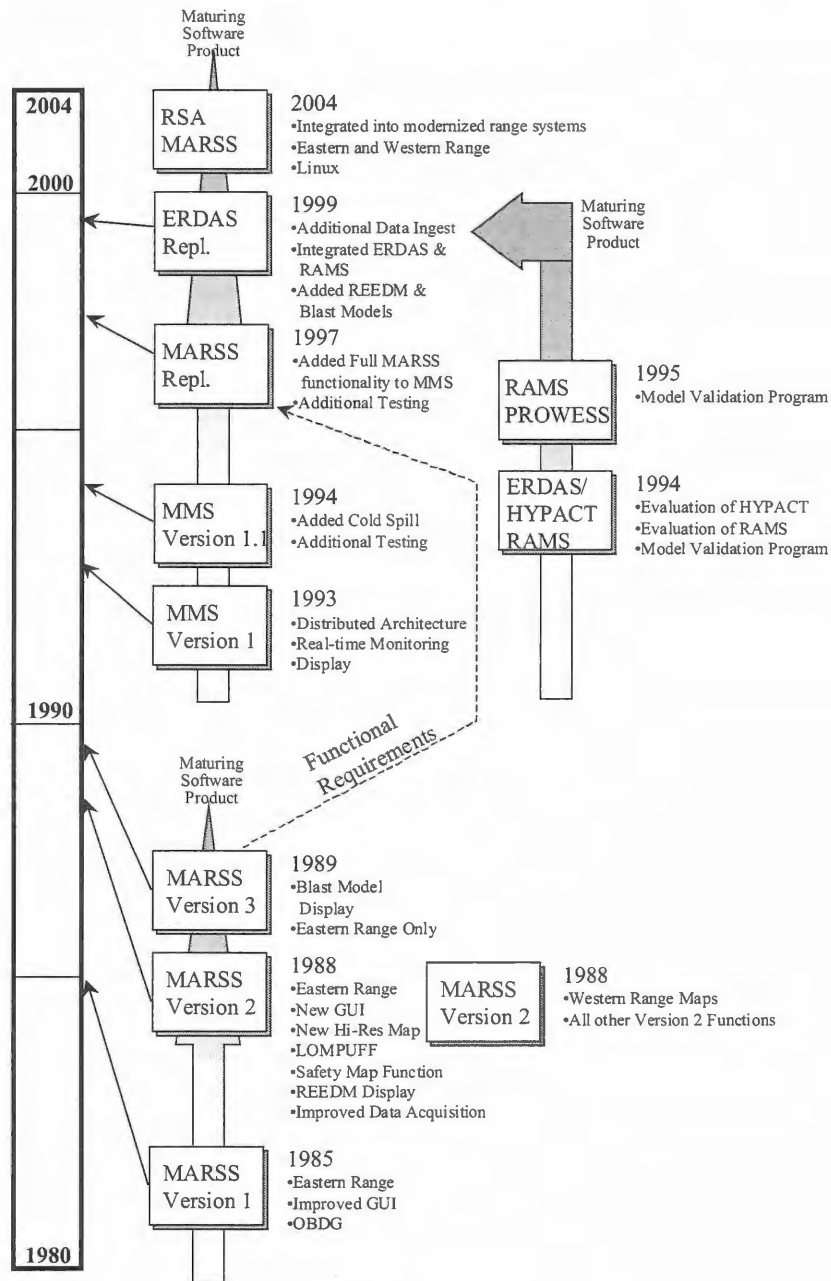

Figure 4. MARSS History